



samlexpower®

**Portable
Solar
Panels**

MSK-90
MSK-135

**Owner's
Manual**

Please read this
manual BEFORE
using your
MSK-90 or
MSK-135.

OWNER'S MANUAL | Index

SECTION 1

Safety Instructions 3

SECTION 2

Description, Applications & Features 5

SECTION 3

Installation & Operation 8

SECTION 4

Troubleshooting & Maintenance 14

SECTION 5

Specifications 16

SECTION 6

Warranty 18

SECTION 1 | Safety Instructions

IMPORTANT SAFETY INSTRUCTIONS

PLEASE READ THE FOLLOWING SAFETY INSTRUCTIONS BEFORE USING THE KIT. FAILURE TO ABIDE BY THE RECOMMENDATIONS MAY CAUSE PERSONAL INJURY / DAMAGE.

The following safety symbols will be used in this manual to highlight safety and information:



WARNING!

Indicates possibility of physical harm to the user in case of non-compliance.



CAUTION!

Indicates possibility of damage to the equipment in case of non-compliance.



INFO

Indicates useful supplemental information.



WARNING!



CAUTION!

1. Although the solar modules are waterproof (Ingress Protection Rating is IP-65), the charge controller MSK-10A attached at the back of one of the modules is not waterproof (Ingress Protection Rating is IP-30). PLEASE ENSURE THAT THE KITS ARE INSTALLED IN DRY ENVIRONMENT
2. The design of the Charge Controller allows ONLY Positive grounding where required. Ground the Positive terminal of the solar array input on the Charge Controller or the Positive terminal of the battery. DO NOT ground the Negative
3. To reduce the risk of injury, charge only 12V Lead Acid Batteries - Flooded, AGM or Gel Cell types. Other types of batteries may be subject to bursting which can lead to personal injury & damage.
4. Comply with battery manufacturer's recommendations
5. Avoid charging damaged, defective or old battery.
6. Ensure correct polarity is maintained when connecting the Charge Controller to the battery - Connect the Positive Battery Clamp (Red) to the Positive Battery Post and the Negative Battery Clamp (Black) to the Negative Battery Post. Reversal of polarity connection will blow the inline protective fuse.
7. When charging, removal of the battery from the vehicle is not necessary provided the battery is being charged in a well-ventilated area.
8. Batteries contain very corrosive diluted Sulphuric Acid as electrolyte. Precautions should be taken to prevent contact with skin, eyes or clothing. If the battery acid makes contact with skin or clothing, flush immediately with water. See a doctor immediately.

SECTION 1 | Safety Instructions

9. Batteries generate Hydrogen and Oxygen during charging resulting in evolution of explosive gas mixture. Care should be taken to ventilate the battery area and follow battery manufacturer's recommendations.
10. Ensure there are no flammable substances, explosive gases, flames, smoke or spark near the battery or the panels.
11. Use caution to reduce the risk of dropping a metal tool on the battery. It could spark or short circuit the battery or other electrical parts and could cause an explosion.
12. Remove metal items like rings, bracelets and watches when working with batteries. Batteries can produce a short circuit current high enough to weld a ring or the like to metal and thus cause a severe burn.
13. If you need to remove a battery, always remove the ground terminal from the battery first. Make sure that all the accessories are off so that you do not cause a spark.
14. Solar panels generate electrical power when exposed to sunlight.
15. Place a dark cover over the panels when handling panels that have bare, un-insulated output wires. Accidental shorting of panel terminals or wiring connected to the panels can result in spark causing personal injury or a fire hazard.
16. It is important that the battery gets fully charged frequently (at least once per week). Otherwise, the battery can become permanently damaged due to under charging. Partially charged batteries can quickly sulfate internally which is an irreversible condition. It is good practice to prevent a battery from being discharged below 50%. Deeper discharging severely shortens battery life.
17. Keep the surface of solar panels clean from dust. Clean with a soft cloth. Do not walk on the panels
18. Avoid solar panel contact with water, acid or alkali.
19. Do not scratch or bend solar panels.
20. Do not disassemble or open the solar panels or the Charge Controller. There are no user-serviceable parts in this Kit .
21. Never allow young children to play with this kit.
22. Do not stack heavy items on top of the solar panels during storage / transportation.

SECTION 2 | Description, Applications & Features

DESCRIPTION

MSK-135 and MSK-90 are 135W / 90W Portable and Foldable Solar Battery Charging Kits designed to charge 12V Lead-acid batteries. The kit can be folded neatly into a carrying case with handle, for easy storage while the kit is not in use.

APPLICATIONS

The kits are perfect for charging and maintaining any 12V battery system in the following applications:

- Automotive, Recreation Vehicles, Trailers
- Boats and marine craft
- Motorcycles
- Air craft
- Cabins and cottages
- Camping
- Construction and farm equipment
- Material handling equipment
- All Terrain Vehicles (ATV) and Snowmobiles
- Disaster / emergency preparedness

FEATURES

Modular and Durable Integrated Design with High Efficiency Polycrystalline Solar Modules



Fig 2.1 Modular, integrated design - MSK-135 and MSK-90

Please see Fig 2.1 above. Basic module is a 45W, 12V nominal high efficiency, Polycrystalline solar panel. MSK-135 consists of 3 x 45W solar panels connected in parallel and MSK-90 consists of 2x45W solar panels in parallel to form solar panel array.

Panels are built with strong anodized aluminum frames and high transparency solar glass for maximum light permeability and high efficiency.

SECTION 2 | Description, Applications & Features

State-of-the-art, PWM Type Solar Charge Controller



Fig 2.2: 10A Charge Controller

Please see Fig 2.2 above. State-of-the-art, 10A rated, Series Type PWM Solar Charge Controller Model MSK-10A ensures efficient, safe and optimum charging of 12V Lead Acid Battery - Flooded, AGM, or Gel Cell. Charging characteristics include Bulk, Absorption, Float and Equalization Stages. Please refer to separate Owners Manual for the Charge Controller for details.

Folding Type of Support Legs with Tilt Adjustment

Please refer to Fig 2.3. Folding type of supporting legs with tilt adjustment mechanism have been provided (3 legs for MSK-135 and 2 for MSK-90).

Each leg consists of 2 sections:

- Spring loaded Supporting Leg (1, Fig 2.3) with 3 Tilt Adjustment Stops (2, Fig 2.3). Spring mechanism keeps the leg in folded position i.e. flush within the panel frame. To extend, the leg is required to be pulled outward and fixed in the required stop with the help of the Tilt Adjustment Arm (3, Fig 2.3) for the desired tilt angle
- Tilt Adjustment Arm (3, Fig 2.3). Tilt angle can be adjusted by resting the Tilt Adjustment Arm at one of the 3 stops (2, Fig 2.3) provided on the Supporting Leg (1, Fig 2.3). This keeps the solar panels at the desired tilt angle. By adjusting the angle of the solar panels throughout the day, maximum sun exposure is achieved yielding maximum power output and faster battery charging.

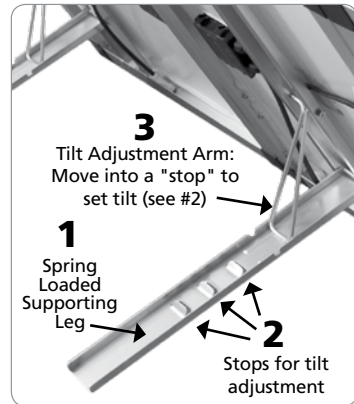

Fig 2.3 Support and Tilting Arrangement

Maximizing Solar Energy Capture and System Efficiency

Please see Fig 2.3 above. Ease of adjusting the azimuth of the solar array i.e. the direction that the face of the solar array points and convenient tilting arrangement allows the solar array to point perpendicular to the sun for maximizing solar energy capture and system efficiency.

SECTION 2 | Description, Applications & Features

Portable and Simple

Please see Fig 2.4. Fold away conveniently into a stylish carrying case with handle, for quick transport or stowage.

Fig 2.4: Folded view and Carrying Case

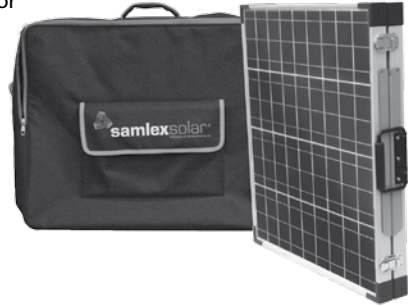

Easy "Plug-and-Charge" Battery Connection

Please see Fig 2.5. Charging starts as soon as battery is plugged to the Charge Controller using 16 ft. of detachable battery cable with Alligator clips (9, Fig 2.5). Additional 16 ft. Extension Cable (8, Fig 2.5) is provided to extend the battery cable to 32ft. Heavy duty, 50A Anderson Type 50B compatible mating connectors (7, 8A, 8B, 9A, Fig 2.5) are used for battery cable connection.

No complicated installation, brackets or electrical diagrams!

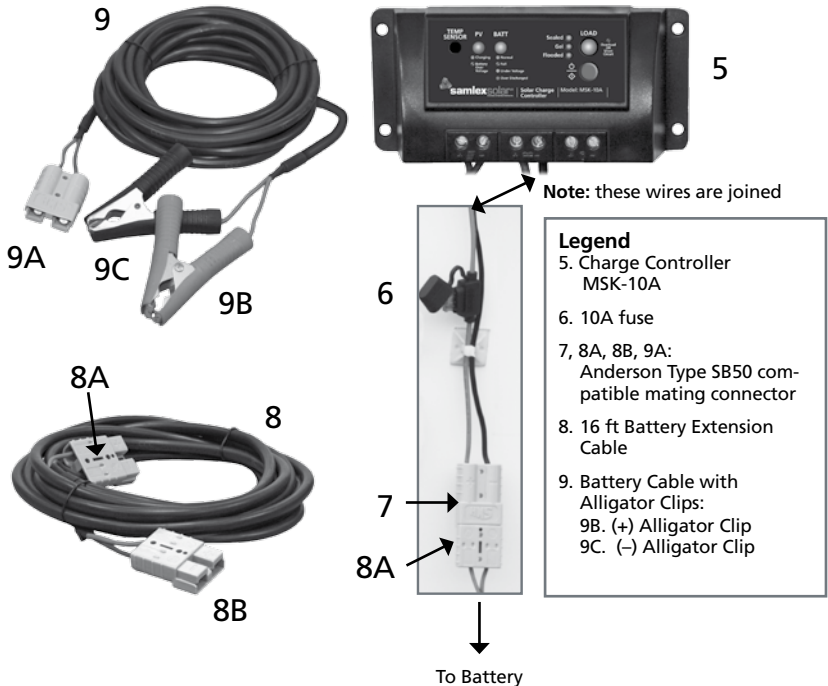

Fig 2.5: Arrangement for battery connection

SECTION 3 | Installation & Operation



WARNINGS & CAUTIONS!

PLEASE READ ALL THE SAFETY INSTRUCTIONS GIVEN IN SECTION 1 BEFORE INSTALLING AND OPERATING THE KIT. FAILURE TO ABIDE BY THE RECOMMENDATIONS MAY CAUSE PERSONAL INJURY / DAMAGE TO THE KIT.

Do not use the unit in wet environment

Please note that the solar modules are waterproof (IP-65). However, the Charge Controller MSK-10A attached at the back of one of the modules is not waterproof (IP-30). Hence, please ensure that the kits are installed in dry environment.

Grounding

The design of the Charge Controller MSK-10A allows only Positive grounding. Ground the Positive terminal of the solar array input on the Charge Controller or the Positive terminal of the battery. Do not ground the Negative.

OVERALL CONNECTION ARRANGEMENT - SOLAR MODULES, CHARGE CONTROLLER, BATTERY AND LOAD

Fig 3.2 (page 11) shows overall connection arrangement of the modules, Charge Controller, battery and load. This arrangement is shown for 3-module, 135W Kit Model No. MSK-135. Arrangement for the 2-module, 90W Kit Model No. MSK-90 is similar except that the 3rd module (3, Fig 3.2) is not there.

Connection arrangement of modules to the Charge Controller

MSK-90 – In the 2-module kit MSK-90, 2 x 45W modules are already connected in parallel to the Charge Controller terminals (5I, Fig 3.2) Through their respective junction boxes (1A, 2A - Fig 3.2). No additional connection is required to be made.

MSK-135 – In the 3-Module Kit MSK-135, the 2 right hand side modules (1, 2 - Fig 3.2) are already connected in parallel to the Charge Controller terminals (5I, Fig 3.2) through their junction boxes (1A, 2A - Fig 3.2). Connect the third module (3, Fig 3.2) on the left. in parallel with the other 2 modules using the provided cable connector (4, 4A, 4B - Fig 3.2). This cable connector has been provided to protect the cables connecting the two right hand side modules (1 and 2, Fig 3.2) From damage due to pinching between module frames when folded. In case proper care is taken when folding the modules to prevent pinching of the cable, this connection can remain in place permanently here after. Otherwise, this connection should be removed when folding the modules for stowage.

Connection of Battery or Battery Bank to the Charge Controller

The following arrangement has been provided for connecting the Charge Controller to the batteries with 16 ft. / 32 ft. of cable:

- Battery Terminals of the Charge Controller (5J, Fig 3.2) are connected to heavy duty, 50A Anderson Type SB50 compatible, 2-pole Battery Connector (7, Fig 3.2) through Inline Fuse and Fuse Holder (6, Fig 3.2)
- 16 ft. Battery Cable (9, Fig 3.2) With heavy duty, 50A Anderson Type SB50 compatible, 2-pole Battery Connector (9A, Fig 3.2) on one end for connecting to the mating

SECTION 3 | Installation & Operation

connector on the Charge Controller side (7, Fig 3.2). Battery alligator clips (9B, 9C - Fig 3.2) are provided on the other end for connecting to the battery.

- 16 ft. Battery Extension Cable (8, Fig 3.2) With heavy duty, 50A Anderson Type SB50 compatible, 2-pole battery connector (8A, Fig 3.2) on one end for connecting to the mating connector on the Charge Controller side (7, Fig 3.2). Another heavy duty, 50A Anderson Type SB50 compatible, 2-pole battery connector (8B, Fig 3.2) is provided on the other end for connecting to second section of 16 ft. Battery cable with Battery Clamps (9, Fig 3.2) For extending the battery cable to 32 ft.
1. If the battery is less than 16 ft. away, use Battery Cable with Battery Clamps (9, Fig 3.2). If the battery is > 16 ft., use the additional 16 ft. Extension Battery Cable (8, Fig 3.2).
 2. Use 10A fuse (e.g. Automotive ATC-10) within 3" from the Positive Battery Alligator Clip 9B (fuse is not supplied). This fuse is required to protect battery cable run against short circuit.
 3. Connect the Battery Alligator Clips to the Battery Terminals. **IMPORTANT: OBSERVE POLARITY.** Be careful to attach the RED Positive Alligator Clip to 'Positive' or '+' of the battery after the fuse mentioned above, and the black Negative Alligator Clip to the 'Negative' or '-' of the battery. If polarity is reversed accidentally, no permanent damage will occur, but the in-line fuses (6 and 10, Fig 3.2) will blow. In this case, correct the polarity and replace the fuses.
 4. Removal of the battery from the vehicle is not necessary provided the battery is being charged in a well-ventilated area.
 5. It is recommended that the kit be attached to the battery at the beginning of each camping event rather than wait until the battery is dead before connecting. This allows the solar charging system to supply the loads on the battery and fully charge it each day.

Connection of DC Load to the Load Terminals of the Charge Controller (load $< 10A$)

The Charge Controller is provided with Load Terminals (5K, Fig 3.2) for powering small DC loads of up to 10A. DC load powered from these terminals provide the following benefits:

- The battery will be protected against deep discharge as the Charge Controller will cut off the load when the battery drops below 11.1V. The load will be automatically re-connected after the battery has recharged to 12.6V.
- The load is protected against overload ($\geq 10A$).

Brief Operational Details of Charge Controller MSK-10A

MSK-10A (5, Fig 3.2) is a 10A rated, series type of PWM (Pulse Width Modulation) Charge Controller. It is based on an advanced design using a Micro-controller for digital accuracy and fully automatic operation. PWM battery charging has been optimized for longer battery life. The unit is designed for user-friendly operation. Only brief operational details of the Charge Controller are given below.

SECTION 3 | Installation & Operation

Connection of DC Load Directly to the Battery (Load > 10A)

If the DC load draws > 10A, connect it directly to the battery through appropriate fuse (locate fuse within 7" of the Battery Positive Terminal).

Separate MSK-10A Charge Controller Manual is available at www.samlexamerica.com to help you make full use of the charging system.

Layout and functions of controls, LED monitoring and operational details of the Charge Controller are given below. Please refer to Fig. 3.2.

5A. **TEMPERATURE SENSOR:** senses ambient temperature for temperature compensation for charging and discharging.

5B. **STATUS LED "PV":**

LED COLOR AND PATTERN	STATUS
GREEN - Steady	"CHARGING" Energy from PV panel(s) is available at the PV panel(s) input terminals and voltage > 6V is also available simultaneously at the Battery Terminals.
GREEN - Fast Flashing	"BATTERY OVER VOLTAGE" - Over voltage disconnect protection has been activated due to high voltage of $\geq 16V / 32V$ at the Battery Output Terminals - PV panel(s) and load have been disconnected.

5C. **STATUS LED "BATT"**

LED COLOR AND PATTERN	STATUS
GREEN - steady	"NORMAL": battery is in bulk stage - normal state of charge of up to 80%
GREEN - slowly flashing	"FULL": battery is in either absorption (boost) or equalization or float stage and pwm regulated voltage charging is active. State of charge is nearly full / completely full - 80% to 100%
ORANGE - steady	"UNDER VOLTAGE": battery under voltage warning signaling has been activated at $\leq 12v / \leq 24v$. Output is still available at Load Terminals Will be reset automatically when voltage rises to 12.2V / 24.4V and LED will go back to steady green from steady orange

SECTION 3 | Installation & Operation

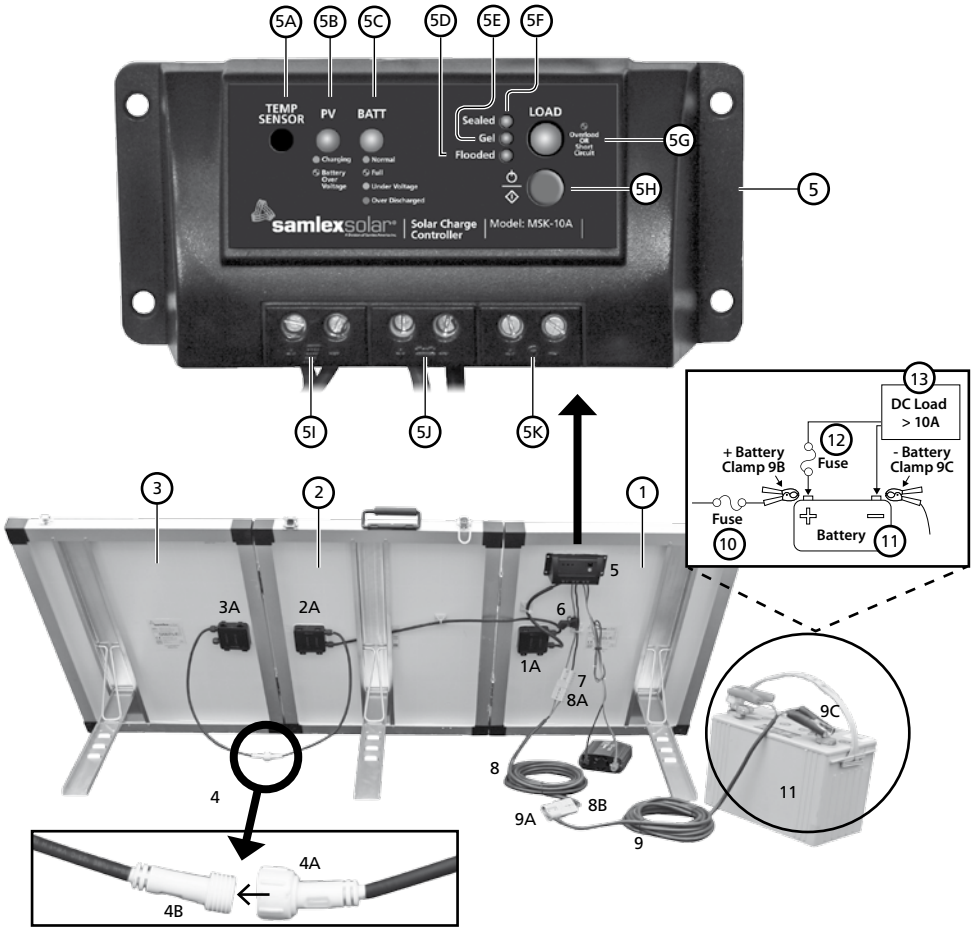

Fig 3.2 MSK-135 LAYOUT

1, 2, 3	3 x 45W Solar Modules connected in parallel (MSK-90 has 2 x 45W Solar Modules 1 & 2)
1A, 2A, 3A	45W Module Junction Box
4, 4A, 4B	2-Pole Mating Connector (for MSK-135) for connecting third Module 3 in parallel with Modules 1 & 2
5 / 5I	Charge Controller MSK-10A (5) / Charge Controller Terminals for Solar Array (5I)
5J / 5K	CHARGE CONTROLLER TERMINALS: for Battery (5J) / for DC Load up to 10A (5K)
5G	Status LED "Load"
5H	Setting Button
6	10A fuse with Fuse Holder
7,8A,8B,9A	50A Anderson Type SB50 Compatible Mating Connectors
8	16 ft Extension Cable for Battery Connections
9	16 ft Cable for Battery Connection
9B, 9C	Alligator Clips for Battery Connection: 9B - Positive; 9C - Negative
10	10A fuse inserted within 3" from Positive Battery Alligator Clip 9B (fuse not supplied)
11	12V Battery
12	Fuse for DC load(s) within 7" of Battery and Terminal (not supplied)
13	DC load(s) drawing > 10A

SECTION 3 | Installation & Operation

RED - steady	<p>“OVER DISCHARGE”: protection against over discharge of battery has been activated at $\leq 11.1V / \leq 22.2V$ and the load has been disconnected.</p> <p>Load will be reconnected automatically at $12.6V / 25.2V$ and the LED will go back to steady green from steady red</p>
--------------	---

- 5D. **Status LED “Flooded”**: Flooded Type of battery has been selected
 5E. **Status LED “Gel”**: Sealed, Gel Cell Type of battery has been selected.
 5F. **Status LED “Sealed”**: Sealed, AGM type of battery has been selected.
 5G. **Status LED “Load” Load Status Indicator**: display the Load Status.

LED COLOR AND PATTERN STATUS	STATUS
RED - Flashing	<p>Over Load or Short Circuit”: Load has been disconnected due to overload or short circuit in the load circuit connected to the Load Terminals</p> <p>Overload: 12.5A for 5 sec – Manual reset by pressing “Set” Button</p> <p>Short Circuit: 35A – First short circuit is reset automatically after 10 sec. Second consecutive short circuit will require manual reset by pressing “Set” Button</p>
RED - Steady	Load is ON

- 5H. **Setting button**:
 - Switch ON and Switch OFF the load connected to the Load Terminals.
 - Select battery type
- 5I. Terminals for connecting Solar Module
 5J. Terminals for connecting Battery
 5K. Terminals for connecting Load(s) - Maximum 10A



CAUTION!

Please note that the Solar Modules are permanently connected to the Input Terminals of the Charge Controller. The modules will start generating power as soon as these are exposed to sunlight. However, there will be no power output from the Charge Controller until the controller is connected to the battery. Make sure that the battery voltage is $> 6V$ in order to start the Charge Controller. The following spurious LED indications may be seen at the Charge Controller and may be disregarded:

SECTION 3 | Installation & Operation

Module(s) are exposed to sunlight and battery has not been connected

- No LED indication

Module(s) are exposed to sunlight, battery is connected and then removed.

- "PV" LED (5B, Fig. 2.3): Steady GREEN

- "Batt" LED (5C, Fig 3.2): Steady GREEN with RED flickering

Setting Battery Type

After connecting the battery, set the Lead Acid Battery Type being used - Flooded, Sealed AGM (displayed and referred to as "Sealed") or Sealed Gel Cell (displayed and referred to as "Gel"). Use Setting Button (5H, Fig 3.2). Press the Setting Button for more than 5 seconds, the original battery type indicator will be flashing. Then press the Setting Button to choose Sealed, Gel, and Flooded battery type. The setting finishes when flashing stops. Status LED corresponding to the battery type selected will be lighted (5D, 5E & 5F, Fig 3.2).

SECTION 4 | Troubleshooting & Maintenance

TROUBLESHOOTING

GREEN STATUS LED "PV" (5B, FIG 3.2) DOES NOT LIGHT

- Solar array input voltage to the Charge Controller has been disconnected.
- Ensure all Solar Module cables are connected correctly and are not damaged.
- Ensure that the solar array is exposed to sunlight.
- Modules are exposed to sunlight. No battery has been connected / battery connection is broken / battery voltage < 6V.
- Ensure the 16 ft. / 32 ft. battery cable between the Charge Controller and the battery is connected correctly and is not damaged.
- Check that fuses (6, 10 - Fig 3.2) are not blown. Be sure the polarity is correct. If fuses continue to burn, the most likely cause is reversed polarity at the battery terminals. It may also be due to some catastrophic failure in the Charge Controller in rare cases.
- Check battery voltage. If the voltage is less than 6V, the Charge Controller will not turn ON.

GREEN STATUS LED "BATT" (5C, FIG 3.2) DOES NOT FLASH SLOWLY

- Indicates that the Battery is not fully charged. In certain circumstances where the battery or battery bank is under constant load, the fully charged state may never be reached long enough for the 'Float' Mode to be engaged. This is common and normal in most RV and Marine applications. It is important that the battery gets fully charged frequently (at least once per week). Otherwise the battery can become permanently damaged due to under charging. Partially charged batteries can quickly sulfate internally which is an irreversible condition. It is good practice to prevent a battery from being discharged below 50%. Deeper discharging severely shortens battery life.

MODULES ARE EXPOSED TO SUNLIGHT AND BATTERY IS NOT CONNECTED; "PV" LED (5B, FIG 3.2) IS STEADY GREEN; "BATT" LED (5C, FIG 3.2) IS STEADY GREEN WITH RED FLICKERING; LOW VOLTAGE OF < 5V AT THE BATTERY TERMINALS

- Module(s) are exposed to sunlight; battery was connected earlier and was subsequently removed. Restore battery connection.

BATTERY APPEARS TO FULLY CHARGED WITH THE SYSTEM CONNECTED, BUT GOES DEAD QUICKLY.

- Battery has failed. This can happen to old batteries and even new ones if not properly cared for. Confirm battery condition with a 100 Amp 'Battery Load Tester' obtained at any auto parts store or ask your dealer to test the battery for you. Replace the battery if necessary.

LEDS "SEALED", "GEL", "FLOODED" (5F, 5E, 5D, FIG 3.2) FLASH SIMULTANEOUSLY

- Over-temperature protection has activated (Heat Sink > 85°C). Input and output circuits will be disconnected and reset automatically when temperature drops to 75°C.

SECTION 4 | Troubleshooting & Maintenance

LED "LOAD" (5G, FIG 3.2) IS RED AND FLASHING

- Output to Load Terminals is shut down due to overload in the load. Manual reset will be required by pressing the Setting Button. Load will be connected after 3 sec
- Output to the Load Terminals is shut down due to short circuit in the load. When first short circuit occurs, the output to the Load Terminals is auto resets after 10 sec. If second short circuit occurs, the output is shut down till it is manually reset 3 sec after pressing the Setting Button

MAINTENANCE

Dust & dirt should be swept off the solar module surface using a soft brush then using a wet cloth to wipe the panel surface to remove remaining dirt & grime. It is recommended that any bird droppings should be removed as soon as possible as it can cause damage to the surface.

SECTION 5 | Specifications

PARAMETER	MSK-135	MSK-90
SOLAR ARRAY		
NOMINAL MAXIMUM POWER AT STC, P _{max}	135W (3x 45W Modules in parallel)	90W (2x45W Modules in parallel)
MAXIMUM POWER VOLTAGE, V _{mp}	17.4V	17.4V
MAXIMUM POWER CURRENT, I _{mp}	7.74A (2.58A per 45W Module)	5.16A (2.58A per 45W Module)
OPEN CIRCUIT VOLTAGE, V _{oc}	21.6V	21.6V
SHORT CIRCUIT CURRENT, I _{sc}	8.52A (2.84A per 45W Module)	5.68A (2.84A per 45W Module)
TYPE OF CELLS / SIZE	Polycrystalline; 156mm X 156mm / 6.14 x 6.14 in	
EFFICIENCY	16.8%	
NUMBER OF CELLS	36 Cell per 45W Module	
MAXIMUM SYSTEM VOLTAGE	1000 VDC	
OPERATING TEMPERATURE	- 40°C to +85°C / - 40°F to +185°F	
INGRESS PROTECTION (IP) RATING	IP 65 (Waterproof)	
STANDARD TEST CONDITIONS (STC) FOR SOLAR MODULE	Irradiance Level: 1000W/m ² Spectrum: AM1.5 Cell Temperature: 25°C / 77°F	
CHARGE CONTROLLER MODEL MSK-10A (Separate MSK-10A Charge Controller Manual is available at www.samlexamerica.com to help you make full use of the charging system)		
TYPE	PWM, Series Type; PWM Frequency 25 Hz	
MAXIMUM OPEN CIRCUIT VOLTAGE (V _{oc}) OF SOLAR ARRAY	50V	
MAXIMUM SHORT CIRCUIT CURRENT I _{sc} OF SOLAR ARRAY / MAXIMUM CHARGING CURRENT	10A	
NOMINAL BATTERY VOLTAGE	12V / 24V Auto sensing: < 18V sensed as 12V and > 18V is sensed as 24V.	
BATTERY TYPE	Lead Acid: Flooded, Sealed AGM, Sealed Gel Cell	
INGRESS PROTECTION (IP) RATING	IP 30 (NOT waterproof. Install in dry environment)	
OTHER COMPONENTS / PARAMETERS		
Fuse and Mating Connector for Battery (Attached to Battery Terminals of Charge Controller)	Fuse: Automotive Blade Fuse Type ATC, 10A Mating Connector for Battery Cable: 50A, Anderson Type SB-50 compatible, 2-Pole Connector	

SECTION 5 | Specifications

PARAMETER	MSK-135	MSK-90
CABLE SETS FOR BATTERY	<p>Cable Set 1: 16 ft. for Battery Connection 2 x AWG # 14 (2.5 mm²) / 16 ft. 50A, Anderson Type SB-50 compatible, 2-Pole Mating Connector on one end Alligator Clips on the other end</p> <p>Cable Set 2: 16 ft. Extension 2 x AWG # 14 (2.5 mm²) / 16 ft. 50A, Anderson Type SB-50 compatible, 2-Pole Mating Connector on both ends</p>	
DIMENSIONS	<p>OPEN: 1651 x 695 x 78mm 65 x 27.36 x 3.07 in</p> <p>FOLDED: 695 x 545 x 120 mm 27.36 x 21.46 x 4.72 in</p>	<p>OPEN: 1102 x 673 x 78mm 43.39 x 26.50 x 3.07 in</p> <p>FOLDED: 673 x 563 x 78 26.50 x 22.17 x 3.07in</p>
Weight	<p>17.9 Kg / 39.46 lbs. – (With bag, cables) 15.5 Kg – 34.17lbs. (Without bag, cables)</p>	<p>12.44 Kg / 27.43 lbs. – (With bag, cables) 10.5 Kg – 23.15 lbs. (Without bag, cables)</p>

Note: Specifications are subject to change without notice.

SECTION 6 | Warranty

2 YEAR LIMITED WARRANTY

MSK-90 & MSK-135 Kits manufactured by Samlex America, Inc. (the “Warrantor”) are warranted to be free from defects in workmanship and materials under normal use and service. The warranty period is 2 years for the United States and Canada, and is in effect from the date of purchase by the user (the “Purchaser”).

Warranty outside of the United States and Canada is limited to 6 months. For a warranty claim, the Purchaser should contact the place of purchase to obtain a Return Authorization Number.

The defective part or unit should be returned at the Purchaser’s expense to the authorized location. A written statement describing the nature of the defect, the date of purchase, the place of purchase, and the Purchaser’s name, address and telephone number should also be included.

If upon the Warrantor’s examination, the defect proves to be the result of defective material or workmanship, the equipment will be repaired or replaced at the Warrantor’s option without charge, and returned to the Purchaser at the Warrantor’s expense. (Contiguous US and Canada only)

No refund of the purchase price will be granted to the Purchaser, unless the Warrantor is unable to remedy the defect after having a reasonable number of opportunities to do so. Warranty service shall be performed only by the Warrantor. Any attempt to remedy the defect by anyone other than the Warrantor shall render this warranty void. There shall be no warranty for defects or damages caused by faulty installation or hook-up, abuse or misuse of the equipment including exposure to excessive heat, salt or fresh water spray, or water immersion.

No other express warranty is hereby given and there are no warranties which extend beyond those described herein. This warranty is expressly in lieu of any other expressed or implied warranties, including any implied warranty of merchantability, fitness for the ordinary purposes for which such goods are used, or fitness for a particular purpose, or any other obligations on the part of the Warrantor or its employees and representatives.

There shall be no responsibility or liability whatsoever on the part of the Warrantor or its employees and representatives for injury to any persons, or damage to person or persons, or damage to property, or loss of income or profit, or any other consequential or resulting damage which may be claimed to have been incurred through the use or sale of the equipment, including any possible failure of malfunction of the equipment, or part thereof. The Warrantor assumes no liability for incidental or consequential damages of any kind.

Samlex America Inc. (the “Warrantor”)

www.samlexamerica.com

Contact Information

Toll Free Numbers

Ph: 800 561 5885

Fax: 888 814 5210

Local Numbers

Ph: 604 525 3836

Fax: 604 525 5221

Website

www.samlexamerica.com

USA Shipping Warehouse

Kent WA

Canadian Shipping Warehouse

Delta BC

Email purchase orders to

orders@samlexamerica.com



samlexamerica®