

PURE SINE WAVE POWER INVERTER

12 Volt DC to 120 Volt AC

MODEL: PMX-1000 PMX-2000PSPT PMX-3000PSPT

**1000W
2000W
3000W**

PRIOR TO USE, READ AND UNDERSTAND
PRODUCT SAFETY INFORMATION.

Failure to follow the instructions may result in ELECTRICAL
SHOCK, EXPLOSION, or FIRE, which may result in SERIOUS
INJURY, DEATH, DAMAGE TO DEVICE or PROPERTY.

Do not discard this information.



Intertek

5022161

Conforms to UL 335, 459
Cert. to CSA Std. C22.2 No. 107.1

IMPORTANT SAFETY INFORMATION

GENERAL SAFETY PRECAUTIONS

Warning! Before using the inverter, read the safety instructions.

- This manual contains important safety and operating instructions for power inverter. This manual will show you how to use your inverter safely and effectively. Please read, understand and follow these instructions and precautions carefully.
- Do not expose the inverter to rain, snow, spray or dust. To reduce the risk of fire hazard, do not cover or obstruct the ventilation openings and do not install the inverter in a zero-clearance compartment.
- To avoid the risk of fire and electric shock, make sure that the existing wiring is in good electrical condition, and the wire size is not undersized.
- This equipment contains components which can produce arcs or sparks. To prevent fire or explosion do not install in compartment containing batteries or flammable materials or in location which require ignition protected equipment. This includes any space containing gasoline-powered machinery, fuel tanks, or joints, fittings, or other connection between components of the fuel system.
- Do not operate near water or in excessive humidity.
- Do not open or disassemble the inverter, and warranty may be voided.

01

- The DC side connections should be firm and tight.
- Do not drop a metal tool on the battery. The resulting spark or short-circuit on the battery or on the other electrical part may cause an explosion.
- Install the inverter in a well-ventilated area. Do not block the front air vents, or the rear air exhausts of the unit.
- Mount the inverter such that the fan axis is horizontal.
- Do not operate the inverter close to combustible gas or open fire.
- Do not operate appliances that may feed power back into the inverter.
- Important: Do not use in a marine application.
- Do not disassemble the unit; take it to a qualified serviceman when service or repair is required. Incorrect reassembly may result in a risk of electric shock or fire.
- To reduce risk of electric shock, unplug unit from outlet before attempting any maintenance or cleaning. Turning off controls will not reduce this risk.
- Do not place the inverter in direct sunlight. The ideal air temperature for operation is between 50° and 80°F.
- Only connect the power inverter to a 12V battery or power supply. Do not attempt to connect the inverter to any other power source, including an AC power source.
- Do not use the inverter with a product that draws a higher wattage than the inverter can provide, as this may cause damage to the inverter and product.

02

PRODUCT MODEL

PMX-1000

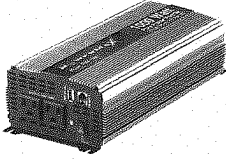

FEATURES

- 120V standard AC outlets (*2)
- USB port(s) – 5V, 2.0A
- Remote control
- LED indicator (Green indicates Power ON ; Red indicates Overload / Interruption in power)
- High-speed cooling fan(s)

PMX-2000PSPT

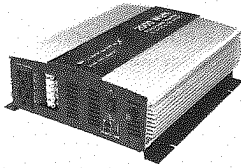

FEATURES

- 120V standard AC outlets (*2)
- USB port(s) – 5V, 2.0A
- Remote control
- LED indicator (Green indicates Power ON ; Red indicates Overload / Interruption in power)
- High-speed cooling fan(s)
- AC Pass through

PMX-3000PSPT

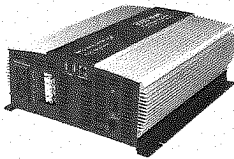

FEATURES

- 120V standard AC outlets (*2)
- USB port(s) – 5V, 2.0A
- Remote control
- LED indicator (Green indicates Power ON ; Red indicates Overload / Interruption in power)
- High-speed cooling fan(s)
- AC Pass through

03

CONNECTING INVERTER CABLES

IMPORTANT: The inverter and power source must be in the OFF mode.

Make sure to connect your inverter only to a 12 volt power supply.

To avoid electrical shock, it is necessary to ground the inverter as well as the device powering it. The inverter should be grounded.

TO GROUND THE INVERTER

1. Turn off and disconnect the inverter.
2. Locate the chassis ground screw on the back of the inverter.
3. Remove the outer nut and loosen the first locking washer.
4. Attach the grounding wire's ring connector to the ground terminal of the inverter.
5. Tighten the locking washer securely. Then, replace the other nut and tighten it securely.
6. Attach the other end of the wire to a properly grounded location:

Vehicle: Connect to the chassis, unpainted frame part, or engine block of the vehicle.

Fixed location: Connect to a ground rod or other appropriately rated ground.

Warning! Make sure that all the DC connections are tight. Loose connections could result in overheating and can be a potential hazard.

04

CONNECTING INVERTER CABLES TO THE INVERTER

1. Locate the Positive and Negative terminals on the inverter.
2. Loosen the screw on the POSITIVE (RED) and the NEGATIVE (BLACK) terminals.
3. Place the POSITIVE (RED) cable into the POSITIVE (RED) inverter terminal.
Place the NEGATIVE (BLACK) cable into the NEGATIVE (BLACK) inverter terminal.
4. Tighten the screw on the POSITIVE (RED) and the NEGATIVE (BLACK) terminals.

SKETCH MAP

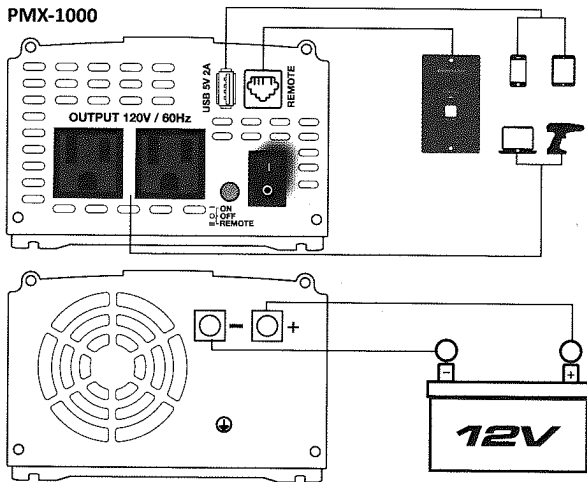

05

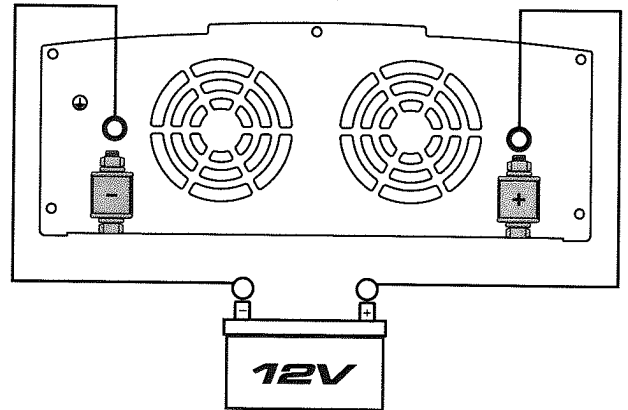
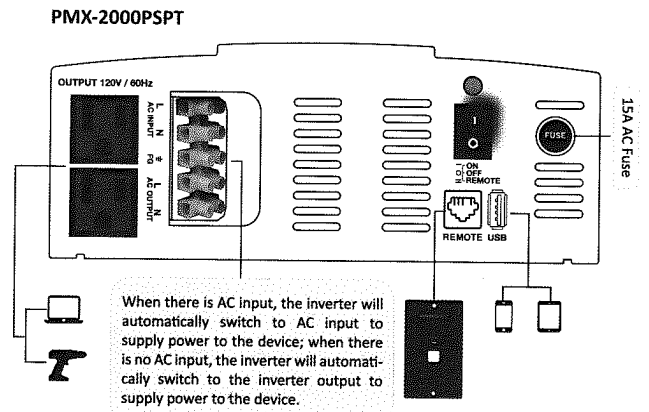

06

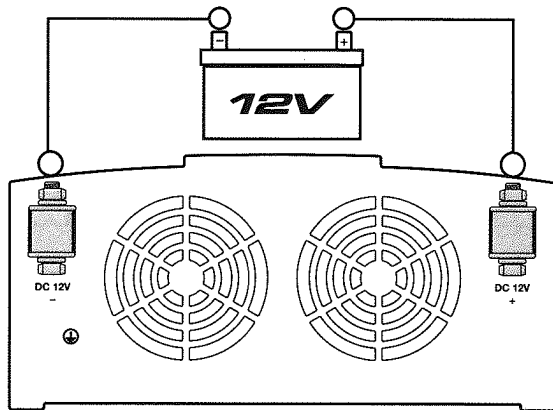
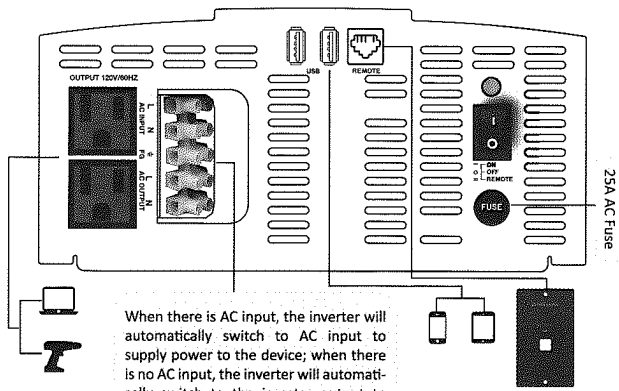

OPERATING INSTRUCTIONS

1. Connect the inverter (see Connecting Inverter Cables section.)
2. Switch the inverter's ON / OFF switch to the ON (I) position.
3. The GREEN LED indicator will light, indicating the inverter is receiving power.
4. Switch the inverter's ON / OFF switch to the OFF (O) position. (The GREEN LED may flash briefly and / or the internal speaker may make a brief "beep". This is normal.)
5. Make sure the device to be operated is turned OFF.
6. Plug the device into the inverter's AC outlet.
7. Switch the inverter's ON / OFF switch to the ON (I) position.
8. Turn the device on.
9. To disconnect, reverse the above procedure.

NOTE: If more than one device is to be powered, start one device at a time, to avoid a power surge and overloading the inverter. The surge load of each device should not exceed the inverter's Continuous Operation wattage rate.

POWER SOURCE

Your average automobile battery at full charge will provide an ample power supply to the inverter when the engine is on. Keep the car running at all times when using the inverter. The actual length of time the inverter will function depends on the age and condition of the battery and the power demand being placed by the device being operated with the inverter.

When possible, recharge your batteries when they are not more than 50% discharged. This gives the batteries a much longer life cycle than recharging when they are more deeply discharged.

The power inverter has a battery low voltage shutdown at $10V \pm 0.5V$ DC. With moderate to heavy loads, this will protect against over-discharging the battery. If the inverter is running only light loads it is advisable to recharge before the inverter low voltage shutdown point is reached.

IMPORTANT: The inverter draws low amperage from the battery with the main ON/OFF switch turned on and no load connected. To prevent battery discharge, turn the inverter off when you are not using it.

LED INDICATOR AND SHUTDOWN PROTECTION

The Green LED lights automatically when the inverter is plugged into a 12 volt DC power source and is turned on. The Red LED lights, the alarm sounds and the inverter automatically turns itself off under the following conditions:

1. When the power input from the vehicle's battery drops to approximately 10.5 volts, the low voltage alarm will sound. When the voltage goes down below 10 VDC, the inverter shuts off. Recharge or replace the battery.
2. When the power input from the vehicle's battery exceeds 16 volts, high voltage protection occurs.
3. The continuous load demand from the equipment or device being operated exceeds the continuous load rating of the inverter. Use a higher capacity inverter or lower rated device.
4. The thermal resistor exceeds $80^{\circ} C$ ($176^{\circ} F$). Allow the inverter to cool. Do not block the cooling slots or air flow over and through the inverter. Reduce the load on the inverter to the continuous rated output.

RESET: To reset after shutdown occurs, switch the inverter's ON/OFF switch to the OFF (O) position. Check the source of the problem and correct. Switch the inverter's ON/OFF switch to the ON (I) position.

IF THE INVERTER'S FUSE BLOWS

Your power inverter is fitted with fuses, which should not have to be replaced under normal operating conditions. A blown fuse is usually caused by reverse polarity or a short circuit within the device or equipment being operated.

If a fuse does blow, take the inverter to a qualified technician for repair.

MAINTENANCE AND STORAGE INSTRUCTIONS

1. Before each use, ensure that all of the inverter's components are in place and in good working condition.
2. After use and before performing maintenance, unplug and disconnect the inverter.
3. Use a clean, dry cloth to wipe external surfaces of the inverter's case.
4. Servicing does not require opening the unit, as there are no user-serviceable parts. All servicing should be performed by qualified service personnel.
5. Store inside, in a cool, dry place, out of the reach of children.
6. Recycle or properly dispose of internal electrical components.

TROUBLESHOOTING

PROBLEM	POSSIBLE CAUSE	REASON/SOLUTION
Low or no output voltage.	Poor contact at terminals OVP/OLP. Using incorrect type of voltmeter to test output voltage.	Disconnect and reconnect the 12V connections. Use a true RMS reading meter.
Red LED is lit.	The battery voltage is below 10 volts. The equipment being operated is drawing too much power. The inverter is too hot (thermal shutdown).	Recharge or replace the battery. Use a higher capacity inverter or decrease the load or device on the inverter. Allow inverter to cool. Check for adequate ventilation. Reduce the load on the inverter to the rated continuous power output.
Alarm sounds continuously.	Input voltage is below 10 volts. Poor or weak battery connection.	Recharge or replace the battery. Check for poor connection to battery. Make sure connection points are clean.
Device does not operate properly when first connected to the inverter.	The inverter may not have the required capacity to operate the device.	Turn the inverter switch OFF and ON, to reset the inverter.

SPECIFICATIONS

MODEL ▶	PMX-1000	PMX-2000PSPT	PMX-3000PSPT
Nominal input voltage	12.8 - 13.2 VDC	12.8 - 13.2 VDC	12.8 - 13.2 VDC
Nominal output voltage	120 ± 10% VAC	120 ± 10% VAC	120 ± 10% VAC
Output frequency	60 ± 3 Hz	60 ± 3 Hz	60 ± 3 Hz
Operating input voltage	10.0-15.0 VDC	10.0-15.0 VDC	10.0-15.0 VDC
Continuous output power	Up to 1000 W	Up to 2000 W	Up to 3000 W
Surge output power	2000 W	4000 W	6000 W
Waveform	Pure sine wave	Pure sine wave	Pure sine wave
Efficiency (typical)	84%	84%	84%
Typical No Load Current	0.9 ADC	1.9 ADC	1.4 ADC
Input overvoltage shutdown	15.0 ± 0.5 VDC	15.0 ± 0.5 VDC	15.0 ± 0.5 VDC
Input undervoltage alarm	10.5 ± 0.5 VDC	10.5 ± 0.5 VDC	10.5 ± 0.5 VDC
Input low voltage shutdown	10.0 ± 0.5 VDC	10.0 ± 0.5 VDC	10.0 ± 0.5 VDC
Output power overload shutdown level	1300 ± 300W	2400 ± 400W	3400 ± 400W
Input fuse	3x40 A	8x30 A	11x35 A
AC receptacles	Two, NEMA 5-15 USA	Two, NEMA 5-15 USA	Two, NEMA 5-15 USA
USB port	One, 5V/2A	One, 5V/2A	Two, 5V/2A

Fieldstone Products PMB 103 • 11161 E SR 70 STE 110 • Lakewood Ranch, FL 34202

Phone: 941-201-8041 • Fax: 941-405-4930

www.powermaxconverters.com

Made in Taiwan
0501339