

INSTRUCTION MANUAL

BatteryMINDER® Model 12248*

Charger / Maintainer / Desulphator-Conditioner



VDC Electronics, Inc.
147 D Woodbury Rd.
Huntington, NY 11743
www.vdcelectronics.com
techsupport@vdcelectronics.com

***NOT for use with
Aviation Type 12-V Batteries**

READ AND SAVE THESE INSTRUCTIONS

TABLE OF CONTENTS

Safety Instructions..... 3

Preparing To Charge..... 5

Charger Location..... 5

DC Connection Precautions..... 6

Qualifying Your Battery: 8

Testing A Filler Cap Or Manifold-type Lead Acid Battery..... 8

Testing With A Hot/Cold Calibrated Hydrometer Tester..... 10

Testing A Sealed, Agm Or Gelled-type Lead Acid Battery 10

Unit With Call-outs 12

Simplified Operating Instructions 13

LED Indicator Functions 14, 15

Detailed Operation Instructions 16

Temperature Sensor ABS-248 (At-the-Battery Sensor) (OPTIONAL)..... 17, 21 - 24

Maintaining Multiple Batteries..... 25

Battery Configurations 26

Troubleshooting - Model 12248 27

Detailed Specifications - VDC Model No. 12248..... 29 - 33

Charging Profile..... 34

For Repair Or Replacement..... 35

Guarantee And Warranty..... 36

**Underwriters Laboratories (UL)
REQUIRED SAFETY INSTRUCTIONS
WARNING**

**TO REDUCE THE RISK OF FIRE,
ELECTRIC SHOCK, OR INJURY TO
PERSON, OBSERVE THE FOLLOWING:**

1. Do not expose charger to rain or snow. It is designed to operate ONLY INDOORS.
2. USE of any attachment not specifically recommended by the battery charger manufacturer for use with this exact model of charger may result in risk of fire & electric shock or injury to person.
3. An extension cord should not be used, unless absolutely necessary. Use of an improper extension cord could result in fire or electric shock. If extension cord must be used be sure:
 - a. Pins on plug of extension cord are the same number, size, & shape of plug on charger
 - b. Extension cord is properly wired and in good condition.

c. Wire size is enough for AC ampere of charger as specified below: Length of cord, feet (meters)
25 (7.6), 60 (15.2), 100 (30.5), 150 (45.6) AWG
Size #18.

4. Do not use charger if it received a sharp blow, been dropped, or damaged.
5. Charger contains no serviceable parts. If it fails for any reason, return to the address shown within for a free replacement under warranty.
6. To reduce risk of electric shock, unplug charger from outlet before attempting any cleaning.
7. **WARNING - RISK OF EXPLOSIVE GASES. WHENEVER YOU WORK NEAR A LEAD ACID BATTERY IT IS DANGEROUS. BATTERIES GENERATE EXPLOSIVE GASES DURING NORMAL BATTERY OPERATION. FOR THIS REASON, IT IS OF UTMOST IMPORTANCE THAT EACH TIME BEFORE USING YOUR CHARGER, YOU MUST READ THIS MANUAL AND FOLLOW THE INSTRUCTIONS EXACTLY.**

To reduce risk of battery explosion, follow these instructions and those published by the battery manufacturer and the manufacturer of any equipment you plan to use in the vicinity of the battery. Review cautionary markings on the products and the engine.

8. **PERSONAL PRECAUTIONS** when working with or near a lead acid battery.
- Someone should be able to hear your voice or close enough to aid you when working near a lead acid battery.
 - Have fresh water and soap nearby case battery acid contact skin, clothing, or eyes. Wear complete eye protection and clothing protection. Avoid touching eyes while working near battery.
 - If battery acid does contact skin or clothing, wash immediately with soap and water. If acid entered the eye, immediately flood the eye with running water for at least 10 minutes and get help immediately.

- NEVER smoke or allow a spark of flame near battery or engine.
- Be extra cautious to reduce risk of dropping a metal tool or auto part onto battery. It might spark or short circuit battery or other electrical part that may cause an explosion.
- Remove personal metal items such as rings, bracelets, necklaces, and watches when working with a lead acid battery. A lead acid battery can produce a short circuit current high enough to weld a ring or the like to metal, causing a severe burn.
- Charger is designed to be used for recharging lead acid batteries ONLY. Never use it to power a low voltage electrical system, or for attempting to recharge dry cell batteries that are commonly used in house holds. These batteries may explode and cause injury to persons and damage property

**NEVER CHARGE A FROZEN BATTERY OR
ONE AT A TEMPERATURE ABOVE 123° F.****PREPARING TO CHARGE**

- a. If necessary to remove battery from equipment to charge. Always remove ground terminal first. Turn off all accessories in the vehicle, so as not to cause an arc.
- b. Be sure area around battery is well ventilated while battery is being charged. Force gas vapors away by using a piece of non-metallic material as a fan.
- c. Clean battery terminals. Be careful to keep corrosion from contacting eyes.
- d. Add distilled water to each cell until battery acid reaches level specified by the manufacturer. This helps Purge excessive gas from cells. Do not overfill. For a battery without caps, follow manufacturer's recharging instructions.
- e. Study all battery manufacturer's specific instructions such as removing cell caps while charging

and recommended charge rates.

- f. Determine condition of battery, by referring to instructions herein, before ever attempting to charge or desulphate any / all batteries.

CHARGER LOCATION

- a. Make sure charger is as far away from battery as output cables permit.
- b. Never place charger directly above battery being charged; gases from battery will corrode and damage charger.
- c. Never allow battery acid to drip on charger when reading specific gravity or filling.
- d. Do not operate charger in a closed-in area or restrict ventilation in any way.
- e. Do not set battery on top of charger.

DC CONNECTION PRECAUTIONS

- a. Connect and disconnect DC output clips from battery only after removing charger power cord from outlet.
 - b. Attach clips to battery posts and twist or rock back and forth several times to make good contact. This tends to keep clips from slipping off terminals and reduces risk of sparking.
- FOLLOW THESE INSTRUCTIONS WHEN BATTERY IS INSTALLED IN EQUIPMENT (VEHICLE, PWC, BOAT, TRACTOR, ETC.) A SPARK NEAR BATTERY MAY CAUSE BATTERY TO EXPLODE. TO REDUCE RISK OF A SPARK NEAR BATTERY:**
- c. Position DC output cord to reduce risk of damage by hood, door, covers, or moving engine parts.
 - d. Stay clear of fan blades, belts, pulleys, and other parts that can cause injuries.
 - e. Check polarity of battery posts. POSITIVE

(POS, P,+) usually has a larger diameter than NEGATIVE -.

f. Determine which post of battery is grounded (connected) to the chassis of equipment. If negative post is grounded see Item N. If positive post is grounded see item P.

N. For negative grounded equipment, connect POSITIVE (**RED**) clip from charger to POSITIVE (POS, P, +) ungrounded post of battery. Connect NEGATIVE (**BLACK**) clip to vehicle chassis or engine block away from battery. Do not connect clip to carburetor, fuel lines, or metal body parts.

g. For positive ground equipment, connect NEGATIVE (**BLACK**) clip from charger to NEGATIVE (NEG, N,) UNGROUNDED POST OF BATTERY. Connect POSITIVE (**RED**) CLIP to chassis or engine block away from battery.

DO NOT CONNECT CLIP TO CARBURETOR, FUEL LINES, OR SHEET METAL BODY PARTS.

Connect to heavy gauge metal part of frame or engine.

h. When disconnecting charger, disconnect charger from AC outlet, then remove clips from vehicle chassis, and battery posts.

Operating instructions for charge information.

FOLLOW THESE STEPS WHEN BATTERY IS OUTSIDE OF VEHICLE OR EQUIPMENT. A SPARK NEAR THE BATTERY MAY CAUSE BATTERY EXPLOSION. TO REDUCE RISK OF A SPARK NEAR BATTERY:

a. Check polarity of battery posts. POSITIVE (POS,P,+) usually has a large diameter than NEGATIVE (NEG, N, -) battery post.

b. Connect (**RED**) charger clip to (POS+) post of battery.

c. Position yourself and free end of cable as far away from battery as possible, then connect NEGATIVE (**BLACK**) charger clip to free end of cable.

d. Do not face battery when making final connections.

e. When disconnecting charger, always do so in reverse sequence of connecting procedure and break first connection while as far away from battery as practical.

DO NOT ATTEMPT TO PERMANENTLY INSTALL ANY CHARGER NOT SPECIFICALLY DESIGNED FOR PERMANENT INSTALLATION, ESPECIALLY IN A WET / MARINE ENVIRONMENT

QUALIFYING YOUR BATTERY:

Preliminary Requirements

NOTE: The BatteryMINDer has no electrical output unless it is connected to a healthy battery.

Testing the BatteryMINDer with a volt or an Amp meter without the unit being connected across a good battery will result in a false reading. If you experience any problems, or are not sure of how to properly use or connect your BatteryMINDer, please e-mail our technical support at:

techsupport@vdcelectronics.com or call our toll-free technical support line 800-379-5579 x206 (Eastern Time). **Be certain to leave your phone number with the area code, time zone and the best time to call.**

To gain the best result from your new charger and to maximize the life and performance of your batteries we strongly recommend you qualify (test) your batteries before attempting to either charge-maintain or desulphate them. Remember, even if you just purchased a “new” battery it may have been subjected to conditions that have caused

“sulphation” such as high temperature ($\geq 80^\circ$).

NOTE: If your battery is new and you are certain it was not subject to conditions that could have caused sulphation*, even before you purchased it, then you can disregard our recommendations for qualifying / testing your battery, before using the BatteryMINDer.

* Such as high temperature storage ($\geq 80^\circ\text{F}$) and/or allowed to self-discharge to 12.4 Volts or lower.

Testing a Filler Cap or Manifold-type Lead Acid Battery

1. Carefully remove all 6 caps or both manifold-type covers from your battery.
2. Check the water-liquid electrolyte level. If the level is low or has ever been below top of plates, severe lead plate sulphation has taken place. Significant recharge/reconditioning time is needed to restore these plates to a condition where the battery can be expected to function normally.

3. Refill each cell with distilled water only to the liquid level indicator found in each cell. **Before proceeding further you must be thoroughly familiar with the safety and operating instructions.**

4. Recharge the battery with the BatteryMINDER to ensure that it is slowly and completely charged before you determine its condition. Allow battery to “rest”* overnight for a minimum of 12 hours before testing with a temperature compensated hydrometer and/or digital type voltmeter only.

*** “RESTED” = a battery that has been as fully charged as possible, using a 3 stage charger (model 12248) and left disconnected from charger or any type load for a minimum of 12 hours.**

5. If the BatteryMINDER battery condition LED lights **(YELLOW)** within 72 hours (single battery) or no balls float in one or more cells, your battery may be too far gone to be fully desulphated. Reconnect battery to your BatteryMINDER and press the Maintenance mode button. Allow battery

to remain in maintenance mode for a minimum of 72 hours, before re-test. Use a hot/cold calibrated hydrometer tester for the most accurate results** (see next page) if you see an increase in the Specific Gravity (SG) or voltage indicating that there is an improvement in the battery’s condition, continue desulphating for an additional 72 hours and retest the battery. Continue this process until the SG or voltage readings no longer increase.

Specific Gravity – Capacity

Temp. Compensated Hydrometer - meter or 4 ball type	Full Capacity Percentage
1.270 (4 Balls floating)	100%
1.250 (3 Balls floating)	75%
1.190 (2 Balls floating)	50%
1.150 (1 Balls floating)	25%
1.120 (0 Balls floating) May denote shorted cell or battery that has been severely discharged and may not be recoverable	0%

TABLE 1

Testing with a Hot/Cold Calibrated Hydrometer Tester

Read the tester instructions carefully for most accurate readings.

1. When using the tester the first time or after a long period of non-use, fill the tester with the battery fluid and let it sit for 1/2 hour or longer. This will soak the balls in order to give you more accurate readings. Failure to do so will give you false readings indicating a battery that may not be in as good a condition as you may have thought.
2. After inserting the tester in a cell, gently tap the tester several times against the inside wall of each cell to dislodge air bubbles that will cause more balls to float than should. Failure to do so will yield false readings that indicate a battery that is not fully desulphated or does not qualify for desulphation.
3. If no balls float in any cell, the cell is shorted. This means your battery is beyond the point of being properly recharged or reconditioned-desul-

phated. Dispose of the battery.

If each cell floats three (3) or more balls (or 1250 on gauge-type), your battery can be desulphated-reconditioned.

4. Always rinse the tester with fresh water after every use. Failure to do so will cause false readings.

Testing a Sealed, AGM or Gelled-type Lead Acid Battery

These batteries have no filler caps or manifold-type covers. Because you cannot gain access to the interior of your battery you cannot test it with a hydrometer.

USE A DIGITAL VOLTMETER ONLY:

1. Recharge the battery with the BatteryMINDer to ensure it is as completely charged as possible, before you determine its condition. Allow battery to “rest” (see pg. 9) overnight for a minimum of 12 hours before testing with a digital voltmeter only.

Failure to test a “rested” (see pg. 9) battery will cause false readings. Be certain to read and understand all safety related instructions (pages 3 to 7) before proceeding further.

2. Measure battery’s voltage, without any load attached. If the voltage is less than 12.4 volts (Typically 50% of charge) the battery may be too heavily sulphated to be fully recoverable. If voltage is 12.4-V or higher full recovery can be expected, given sufficient time (average 1-2 weeks for batteries that are heavily sulphated).

3. Connect the BatteryMINDER to the battery.

4. Charge battery to its maximum level. Press Maintenance-Float (select Battery type) button, if it does not go into this mode automatically. Allow battery to remain for a minimum of 72 hours before retesting. If improvement is seen, continue until battery voltage reaches full capacity level or no further increase is seen.

OCV=Open Circuit No Load Voltage

OCV - “Rested” Voltage	Full Capacity Percentage
12.9 - 13.1 Volts	100%
12.6 - 12.9 Volts	75%
12.4 - 12.6 Volts	50%
12.2 - 12.4Volts	25%
12.0 - 12.2 Volts	0%
<11 Volts = shorted	

TABLE 2

Note: OPTIMA brand “Yellow Top” starter/ deep cycle batteries have a fully charged “resting” voltage of 13.1 (OCV). Increase above values accordingly.



- 1) Battery clip cordset w/ qwik connect plug (pgs.13, 16)
- 2) Ring terminal cordset w/ qwik connect plug (pgs. 13, 16)
- 3) Mounting tabs
- 4) Input power cordset (pg. 13, 18)
- 5) Output cord w/ qwik connect plug (pg. 13, 16)
- 6) Temperature sensor input connector (pg. 13, 17, 21)
- 7) Charge rate selection button (pg. 13, 17, 18)

- 8) Battery type selection button (pgs. 13, 17, 18)
- 9) Stop/Restart selection button (pgs. 13, 17, 18)
- 10) LED indicators for power, connection, fault, battery condition, charge status (pgs.13-15, 18-20, 24)
- 11) 12 Volt Power cordset (Optional)
- 12) Temperature sensor with cord and ring terminal (pgs. 17, 21 - 24) (Optional)

Simplified Operating Instructions

(Read and thoroughly understand ALL SAFETY Instructions on pages (3-7) and Qualifying Your Battery pages 8-11, BEFORE proceeding further.

1. Attach a battery connector assembly (supplied) to output cordset of charger, either the clips or ring terminal assembly, - NEVER BOTH at same time.
2. Attach output to battery terminals-**RED** band =Positive + **BLACK** band = Negative.
2-a: Attach temperature sensor ABS-248 (if supplied) to battery and then to charger* (if required).
3. Select desired charge rate, 2 A for small batteries, 4 A for medium or 8 A for deeply discharged, large or multiple batteries. **Charger will automatically start in Gel and 2 Amp modes when first plugged into 120 Vac power** and has to be unplugged from wall or shut off by pushing Stop/Restart button. Reset to correct modes, if required.
4. Select Correct battery type: Flooded (wet-filler caps or manifold, Sealed AGM ["dry"] or Sealed Gel)**
5. Plug AC power cord into 120 Vac electrical outlet. Observe REVERSED Polarity LED indicator. If lit **RED**, reverse battery connector attachments on battery.
6. Observe Power On - Error Indicator, LED Must be lit **GREEN*****.
7. Observe **GREEN** LED indicator labeled Charge-Float = Solid when charging, Blinking when maintaining battery(s). May return to solid **GREEN** intermittently or if power interruption occurs, to Gel – 2 A modes.
IF IN DOUBT REGARDING ANY OF THE ABOVE, REFER TO FULL INSTRUCTIONS

* See detailed instructions for need and method of properly connecting sensor to battery, pgs. 21 - 24.

** IMPORTANT If in doubt about what type, consult with seller or manufacturer of battery(s), before going further. Choosing the wrong setting will cause over or under charge, leading to shortened battery life or generating potentially hazardous hydrogen gas.

*** See full instructions if not lit **GREEN**.

LED INDICATOR FUNCTIONS -- Tables 3 (top) and 4 A&B (bottom)

		Battery Condition Indication
Battery connected BEFORE full Charge:	Vb<11V	YELLOW
	Vb>11V	GREEN
If Stop/Restart Button is Pressed during charging mode		STOPS CHARGING AND ALLOWS RESET OF ALL SELECTIONS
Battery Sulfation check (AFTER FULL CHARGE):	Vb<11V	YELLOW
	Vb>11V	GREEN
Battery Sulfation check (AFTER FULL CHARGE):	Vb<12.5V*	YELLOW
	Vb>12.5V*	GREEN
*12.75V for Gel battery. *12.75-V for AGM battery setting. 12.5-V for Flooded battery		

LED Status - (Power / Error and Charge LEDs)	POWER / ERROR		CHARGE - FLOAT
	GREEN	RED	GREEN
A.C. power disconnected, battery connected correctly	OFF		OFF
A.C. power connected, battery connected	GREEN		OFF
A.C. power connected, battery connected (press Stop/Restart button)	GREEN		ON
At Soft mode, Bulk charge mode, Absorption mode	GREEN		ON
In Sulphate check mode Float charge mode	GREEN		FLASH
A.C. power connected Reversed Battery Polarity	RED ON		OFF
A.C. power connected, charger output Clip shorted	RED ON		OFF
A.C. power connected, battery voltage is less than 3V	RED ON		OFF
Timed-out when in SoftStart or Bulk mode	RED FLASH		OFF
Timed-out when in Absorption mode & Forced to Float mode	RED FLASH		FLASH
Battery Fault / Battery Weak	RED FLASH		OFF

LED INDICATOR FUNCTIONS

LED indicators refer to charger label at right

	GREEN	GREEN	GREEN
	2A	4A	8A
2A	ON	OFF	OFF
4A	OFF	ON	OFF
8A	OFF	OFF	ON

TABLE 5

	GREEN	GREEN	GREEN
	GEL	AGM	FLOODED
GEL	ON	OFF	OFF
AGM	OFF	ON	OFF
FLOODED	OFF	OFF	ON

TABLE 6

BatteryMINDER®

Charger / Maintainer / Full Time De-Sulfator - Conditioner
12-Volt @ 2/4/8 Amp
Model 12248

For Lead-Acid Batteries ONLY

VDC Electronics, Inc.
800-379-5579 (ET)
www.batteryminders.com
U.S. Patented & Patent Pending

8 A
4 A
2 A

AGM
FLOODED
GEL

MAINTENANCE (FLOAT)
PRESS

PRESS
Select Battery Type

PRESS

PRESS
Stop Restart

Green = Power ON
ERROR:
Red = Polarity Reversed / Battery = less than 3-Volts*
Red (Blinking) = Battery not fully charged - charger in float-maintenance mode*

Battery Condition Indication
Power On & Battery Connected
Before Start Charge:
Green = OK - Accepted
Yellow = Weak / Sulfated / Deep Discharge*
After Charge:
Green = Good
Yellow = Sulfated / Weak*

Charge - Float
Green (solid) = Charging
Green (blinking) = Float (maintenance)

*See Instruction Manual
Hold for 5 sec. for full reset

Detailed Operation Instructions Model 12248

After carefully reading and understanding the Safety Instructions contained in this manual (pages 3 to 7) and having evaluated your battery as described in Qualifying Your Battery (pages 8 to 10) you are properly prepared to begin using your charger.

1. Attach output cord of charger to either the Battery Clip(s) Assembly (BCA) (supplied) or the Ring Terminal Assembly (RTA) (supplied) depending on your preference. However never use both assemblies at the same time for any reason whatsoever.

Never use either of these assemblies on any other charger or for any other purpose such as improvised “jumper cables”, etc.

Using the RTA on batteries remaining in their normal use location (in same place they are regularly installed will normally prove the safest and most

convenient. If you have several applications you may wish to purchase additional Ring Terminal Assemblies (RTA) available from your dealer or VDC Electronics, Inc. directly.

Note: this assembly contains a 15 Amp automotive type fuse and is replaceable should for any reason it were to blow. Never replace this fuse with any type whose rating is higher than 15 Amps, as seriously harmful results may occur.

2. Identify the positive and negative posts or connections on your battery, usually clearly designated with the polarity markings of + (positive) and – (negative). If you have previously installed the RTA referred to in 1. above, you need only to press the connector plug of the charger’s output cord into the mating plug of the RTA. Push firmly and do not leave any space between them.

Correct polarity and a good connection will be your reward. Attach the **BCA** to the proper battery posts, clamps or screw terminals, depending on type of battery. **ALWAYS connect the negative (Black) clip to a metal grounding point (Negative ground installations such as most modern cars, trucks, boats, RVs, etc.) as far away from battery as possible for maximum safety. Never connect to any type of fuel line.**

Note: Older vehicles or other devices may be **Positive ground installations** requiring different connection recommendations. If unfamiliar or unsure which battery type of grounding system you have, check with our Tech Support personnel before proceeding further.

Note: Temperature compensation Sensor Assembly (Part# ABS-248) (OPTIONAL). See pages 21 - 24 for full detailed instructions.

3. Determine the type of battery you wish to charge. When certain press the **Select Battery**

Type button. The most common is the **Flooded** kind, distinguished by removable filler caps (6) or two (2) manifold covers (Maintenance-Free) which should not be removed unless specifically allowed by the battery manufacturer. The second most popular is the **Absorbed Glass Mat (AGM)** sealed-valve regulated type. Lastly is the sealed valve regulated **Gel** battery.

Note: If unsure of your battery type, check with the battery seller, manufacturer or our Tech Support before proceeding further. The normal (default) setting of your charger is GEL, as this is the lowest voltage output and thus the one least likely to cause your battery to be overcharged, should you incorrectly select the wrong battery type. However be aware that using the wrong setting for a particular type battery can dramatically shorten its life and/or cause potentially explosive gas to be emitted from the battery.

4. After selecting battery type, determine the correct charge rate for your particular battery. Small batteries (< 10 AH) should be charged at the 2 Amp setting rate. Larger types (10-30 AH) such as used in motorcycles, PWC, etc. are best charged at the 4 Amp rate setting. For batteries whose capacity rating is greater than 30AH or a fast recharge is needed set charger to the 8 Amp rate. If unsure or recharge time is not important, always choose a low setting (2 or 4 Amp).

Note: The safest procedure is to choose the lowest possible setting when in doubt or recharge time is not important, as there may be conditions such as an internally damaged battery that cannot be reliably detected.

5. After selecting both battery type and charge rate, plug the unit's Power cord into a standard – grounded 120 Vac electrical outlet. The Power ON LED Indicator will light **GREEN**. If it does not light

GREEN check the outlet to be sure it is functioning. In addition, be sure if outlet is controlled by a switch, no one will accidentally shut off the power to the outlet. Check for correct polarity = (no ERROR **RED** LED Indicator). If ERROR Indicator is lit, reverse the charger's output connections to the battery.

6. Press the Stop/Restart button. The Charge – Float LED Indicator will light **GREEN**. The charger will now begin charging by first checking the battery to determine its voltage and ability to accept a charge. Should the battery not have a normal fully discharged voltage (10.5-V minimum) the unit will begin charging in the “Soft-Start” mode to determine if the battery can be safely charged. If it cannot, the Power ON – Error LED will flash **RED** and charging will be stopped. Battery should be carefully checked under a load by a qualified person before further attempting to charge it.

Note: If the battery does not have a minimum no load OCV (Open Circuit Voltage) of 3 volts, the ERROR LED will light RED and charger will reject battery.

No further effort should be made to charge this battery with this charger or any charger. Discard this battery, unless it has just been subjected to a long period of continuous discharge under a load such as can occur with leaving lights on or cranking an engine excessively. Allow such a battery to “Rest” for several hours (overnight if possible) before determining if it is defective. Be very suspicious of any 12-V battery that does not have at least 11-Volts (OCV) before it is recharged. It may well be seriously damaged and unsafe for any type of use or recharge. The unit’s Battery Condition Indication LED will help you determine if battery is less than 11-

Volts (**YELLOW**) or greater than 11-Volts (**GREEN**)

7. After battery has been fully charged, the **GREEN** Charge-Float LED Indicator will begin blinking. It will continue to blink indefinitely, unless unit is disconnected from battery or Stop/Restart button is pressed. Should battery be unable to be fully charged, the LED will not blink and the **RED** Error LED will blink. Battery may not be able to be fully charged, may be too large or too deeply discharged to be fully charged in the normal time allowed by charger. If you are certain battery is not defective, having read and understood completely all of the above concerns and conditions, proceed to restart the charger by pressing and holding the Stop/Restart button for approx. 5 seconds until all LEDs Flash. This allows charger to begin charging battery again.

If battery is not defective it should be able to be fully charged after being restarted. After sufficient time has lapsed the **GREEN** charge LED Indicator will blink confirming when / if battery is now fully charged.

Note: If attempting to charge more than one battery at a time it is very likely the charger will need to be restarted as described in order to completely charge multiple batteries. We do not recommend charging more than one battery at a time without confirming the individual condition of each battery and monitoring the charging and batteries closely. A better solution is to charge each battery separately using model 12248 BatteryMINDer and then connect them together, if desired for long term maintenance-float charging. We suggest your reading the detailed specifica-

tions on pages 29 - 34, including the additional LED indicator functions (pgs. 14 - 15) not already covered above.

After carefully reading these instructions and Troubleshooting (pgs. 27 - 28) sections, should you still have questions, please e-mail our technical support department at:
techsupport@vdcelectronics.com.

Allow up to 3 business days for a detailed response to your questions. Always identify the model number of the product and revision letter of this manual contained on this page below. Without this information we may not be able to assist you correctly.

If your questions have already been answered in this manual you can expect a response referring you back to this manual and the specific page(s).

INSTRUCTIONS:**TEMPERATURE SENSOR Type: ABS-248
(At-the-Battery Sensor) (OPTIONAL)**

If battery is being charged or maintained in temperatures as low as 32°F to a high of 125°F this sensor must be used.

Congratulations on purchasing the most advanced charger-maintainer-desulphator conditioner on the market today. Read your manual carefully to understand all of its features. If you purchased the optional At-the-Battery Temperature Sensor, please read and fully understand all of the following before beginning your installation.

Do NOT modify by extending or shortening the extension cord.

Your first choice should be to connect it to the Negative (-) post (clamp or screw) of the battery. This is the best location to sense the temperature of the battery.

The second choice is to place it as close to the battery as possible. Attachment of the sensor to the side or top of battery is also a possible option, under the right circumstances. Be careful to ensure it will not come loose in service.

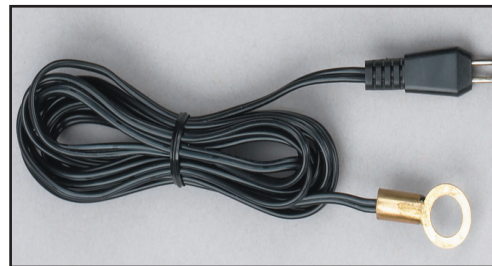

Finally, if placing the sensor on the battery is not practical, place it where the ambient temperature the battery is exposed to (surrounded by) can be sensed. When properly installed on the battery, your charger is set to provide your battery with what it needs to out-live and out-perform any similar battery used in the same application-conditions, by a factor of two (2).

Temperature has a direct effect on the life of a battery. The design life of the battery is based on an average annual temperature of 25°C (77°F). As the temperature increases above 25°C (77°F), the life of the battery decreases. The chart below shows the effects of temperature.

Effects of Temperature on Battery Life*		
Maximum Annual Average Battery Temperature	Maximum Battery Temperature	Percent Reduction in Battery Life
25°C (77°F)	50°C (122°F)	0%
30°C (86°F)	50°C (122°F)	30%
35°C (95°F)	50°C (122°F)	50%
40°C (104°F)	50°C (122°F)	66%
45°C (113°F)	50°C (122°F)	75%
50°C (122°F)	50°C (122°F)	83%
25°C (77°F)	50°C (122°F)	0%

For example: If a battery’s design life is 10 years at 25°C (77°F), but the average battery temperature is 35°C (95°F), the life of the battery will be only 5 years a 50% decrease.

*GNB Industrial Power, A Division of Exide Technologies, Section 92.30 Part No. Z99-Mar/Sep I&O REV 10/01

The chart below shows the need to regulate the output voltage of the charger to ensure against over or under charging your battery over a wide range of temperatures. Using your At-the-Battery Sensor will accomplish this better than any other known method.

AGM Charge and Float Voltages at Various Temperature Ranges**					
Temp °F	Charge		Float		Temp °C
	Optimum	Maximum	Optimum	Maximum	
≥120	13.60	13.90	12.80	13.00	≥49
110 – 120	13.80	14.10	12.90	13.20	43 – 49
100 -110	13.90	14.20	13.00	13.30	38 – 43
90 – 100	14.00	14.30	13.10	13.40	32 – 38
80 – 90	14.10	14.40	13.20	13.50	27 – 32
70 – 80	14.30	14.60	13.40	13.70	21 – 27
60 – 70	14.45	14.75	13.55	13.85	16 - 21
50 – 60	14.60	14.90	13.70	14.00	10 - 16
40 – 50	14.80	15.10	13.90	14.20	4 - 10
≤40	15.10	15.40	14.20	14.50	≤4

**East Penn Technical Manual of Valve-Regulated Lead-Acid (VRLA) Absorbed Glass Mat (AGM) Batteries, E.P.M. Form No. 0139 Rev. 3/04
 Note: The above chart shows the Charge and Float voltage ranges v. temperature for sealed 24-Volt AGM type batteries. Values will differ for sealed Gel or Flooded (filler cap) or maintenance-free types.

Gel Charge and Float Voltages at Various Temperature Ranges**					
Temp °F	Charge		Float		Temp °C
	Optimum	Maximum	Optimum	Maximum	
≥120	13.00	13.30	12.80	13.00	≥49
110 – 120	13.20	13.50	12.90	13.20	44 – 48
100 - 109	13.30	13.60	13.00	13.30	38 – 43
90 – 99	13.40	13.70	13.10	13.40	32 – 37
80 – 89	13.50	13.80	13.20	13.50	27 – 31
70 – 79	13.70	14.00	13.40	13.70	21 – 26
60 – 69	13.85	14.15	13.55	13.85	16 - 20
50 – 59	14.00	14.30	13.70	14.00	10 - 15
40 – 49	14.20	14.50	13.90	14.20	5 - 9
≤39	14.50	14.80	14.20	14.50	≤4

**East Penn Technical Manual of Valve-Regulated Lead-Acid (VRLA) Gelled Electrolyte (gel), E.P.M. Form No. 0139 Rev. 3/04
 Note: This chart shows the Charge and Float voltage ranges v. temperature for sealed 24-Volt Gel type batteries. Values will differ for sealed AGM, Flooded (filler cap) or maintenance-free types Manifold cover(s).

MAINTAINING MULTIPLE BATTERIES

BatteryMINDer 12248 maintenance charger Desulphators can be used to **maintain** up to six (6) 12-volt batteries at a time, providing each battery is fully operational (no dead-dying cells), free of sulphate and meeting the minimum full charge “rested” (see pg. 9) voltage of 2.13 volts / cell, after being fully desulphated. Press the Maintenance - Float charge button immediately to ensure BatteryMINDer is in the proper mode for maintenance charging-desulphating, immediately after making proper connection to the batteries. ALL batteries Must be properly tested to ensure they are in good condition (no dead-dying cells or excessive sulphation) before maintaining them in multiples. Only healthy, fully desulphated batteries should ever be MAINTAINED in sets of 2 or more. Test each cell of All filler cap batteries using an accurate, temperature compensated hydrometer. Test sealed (no filler caps) batteries using an accurate, DIGITAL type ONLY, voltmeter. The Minimum voltage Must not be less than 2.13

volts / cell after fully charging battery and letting it “Rest*” for 12 hours minimum, before testing. If battery voltage is less than 2.13 / cell you must first desulphate it until you reach a “Rested*” voltage of 2.13 volts / cell.

Attempting to desulphate more than one (1) battery at a time will yield very poor results, as the strongest (healthiest) and not the weakest (most sulphated) battery will receive the majority of the desulphation pulse energy. Exception is when two batteries are identical and have been used in parallel or series with each other during their entire life.

Never mix batteries of different type construction / chemistry, or condition (old with new). ALWAYS test each individual battery to be certain it is healthy and free of sulphate before attempting to charge or maintain them, either as a single battery or in sets. NEVER connect multiple batteries together for charging purposes using less than #18 Gauge insulated wire.

(*see pg. 9)

VDC Electronics, Inc. does not make nor can it supply or recommend, any type of wire harness to connect individual batteries for the purpose of charging them in groups, due to the many battery terminal sizes and configurations that exist. See diagram (adjacent) for the various and most common multiple battery configurations.

Battery Configurations

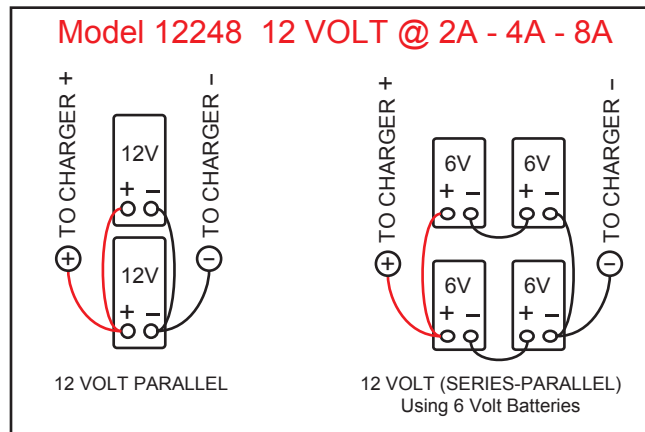

Troubleshooting - Model 12248

We use the word “Indicator” to mean the various LEDs (Light Emitting Diodes) showing the various faults, modes, and conditions of the battery and / or charger.

The words “unit”, “charger” or “recharger” means your model 12248 BatteryMINDER

Problem:

Power ON indicator does not light

Solution:

Check electrical outlet. If controlled by a wall switch be sure switch is on and try to prevent accidental shutting it off while charger is working.

Problem:

ERROR indicator lights **RED**
(several possibilities can be the cause)

Solution:

1. Output leads - connections to battery may be reversed. Switch (reverse) connections at battery
2. If still remains **RED** check battery voltage. If 3-Volts or less battery may be damaged and should not be recharged. If battery was just recently removed from a load (headlights, door lights, etc. or vehicle not used for extended time without a charger-maintainer, allow battery to “recover” by letting it “rest” without a load. If battery is healthy and just deeply discharged it should recover its

voltage (rise above 3 volts) sufficiently to allow charger to begin an attempt to fully recharge it. If after battery has “rested” (see pg. 9) it may not be able to be recovered – recharged. It should be safely discarded – recycled.

Problem:

ERROR Indicator lights **RED** and is **blinking**

Solution:

1. Battery(s) may be weak, heavily sulphated, or too large to fully charge before unit times out. Allow battery to remain in Maintenance-Float mode for 72 hours or more and then attempt to recharge again.
2. Battery may be so large it may require a second full recharge. Repeat recharge by pressing and holding Stop/Restart for 5 sec. until ALL LEDs light. Reset charge rate and battery type, if needed.
3. If recharging multiple batteries, 2 or more complete recharge cycles may be needed. Repeat full recharge by pressing Stop/Restart button again. If still **RED** - blinking, you may need to charge each battery separately.

Problem:

Battery Condition Indicator lights **YELLOW**
(After battery has been completely charged)

Solution:

Battery still has an unacceptable level of sulphation

and must stay connected to charger and remain in Maintenance-Float mode (**GREEN** blinking indicator) for 72 hours or longer. Then stop charger by pressing Stop/Restart button and observe Indicator. If still **YELLOW** repeat (up to 3 full cycles) or until indicator lights **GREEN**.

Problem:

Battery Condition Indicator lights **YELLOW** (May be several causes)
(Before battery is completely charged)

Solution:

Battery can be weak due to sulphation, self discharge or was very deeply discharged.

Attempt a full recharge and recheck after completion. If still **YELLOW** follow procedure for (After battery has been completely charged.)

Problem:

Charger Indicators show battery is fully charged, but fails to provide good cranking, lighting or equipment run time, as it did when newer.

Solution:

You may have chosen too high a charge rate (4A or 8A) for the size, capacity and / or condition of your battery, repeat full recharge cycle at a lower charge rate and leave in maintenance-float mode for 72 hrs. before retesting.

Note: Slow charging in most cases, is preferable to higher

(faster) rates of charge.

Problem:

Error and Charge LEDs blink simultaneously

Solution:

Charger has timed out before battery has completely charged. Reset unit. Repeat reset - full recharge by pressing Stop/Restart button and holding it down until ALL LEDs flash. Reset charge rate and battery type, if needed. Press Stop/Restart button to begin full recharge.

Problem:

Unit goes in to 2A & GEL mode.

Solution:

1. Charger has lost connection to battery, or lost AC power and battery is weak. Ensure that connections are sound and power is not being interrupted.
2. Battery has fallen below 12.5-V while in Maintenance-Float mode. This can occur if the battery is connected to a load, if the battery is sulfated or if there is a bad cell. Disconnect from any load, check the battery for a bad cell and restart charger.

DETAILED SPECIFICATIONS - VDC Model No. 12248

14.1V / 14.4V / 14.6V---2/4/8A MCU controlled H.F. Battery Charger

Note: This equipment has been tested and found to comply with the limits for a Class B digital device, pursuant to part 15 of the FCC Rules. These limits are designed to provide reasonable protection against harmful interference in a residential installation. This equipment generates, uses and can radiate radio frequency energy and, if not installed and used in accordance with the instructions, may cause harmful interference to radio communications. However, there is no guarantee that interference will not occur in a particular installation. If this equipment does cause harmful interference to radio or television reception, which can be determined by turning the equipment off and on, the user is encouraged to try to correct the interference by one of more of the following measures:

- Reorient or relocate the receiving antenna.
- Increase the separation between the equipment and receiver.
- Connect the equipment into an outlet on a circuit different from that to which the receiver is connected.

Electrical Parameters

Input Voltage: 90-140 Vac

Input Frequency: 50/60 Hz

Unloaded input current: 80 mAac

Input Current consumption at 120Vac input, output 13V 8A loading (UL1236) Approx: 2Aac

DETAILED SPECIFICATIONS - VDC Model No. 12248 (con't.)

- Charging Output Control Characteristics
- Charging Flow : Battery condition detect>Soft Start Charge>Bulk Charge>Absorption Charge>Sulphate Check>Float Charge
- Soft Start Charging Activity conditions: Battery Voltage is over 3 Vdc and less than 10.5Vdc (the charger will start at 2A mode & Gel mode automatically)
- Soft Start Charging output current control: (2A / 4A / 8A mode) 0.5 / 1 / 2 \pm 0.25 Adc
- Soft Start Charging Time Limited: (Stop charge If battery cannot be charged over 10.5V after 6 hrs, error LED flash indicated) 6 \pm 0.25 Hours
- Bulk Charging Activity conditions: Battery Voltage is over 10.5Vdc (the charger will start at 2A mode & Gel mode automatically)
- Bulk Charging Current control at 2A mode: (Selected by pressing Charge Rate Button) 2 +0.35 / -0 Adc
- Bulk Charging Current control at 4A mode: (Selected by pressing Charge Rate Button) 4 +0.40 / -0 Adc
- Bulk Charging Current control at 8A mode: (Selected by pressing Charge Rate Button) 8 +0.45 / -0 Adc
- Max. rated output voltage and current: 13.0V at 8Adc 14.6V at 6.5Adc
- Bulk Charging Time Limited: (Stop charge If battery cannot be charged reach 14.1/14.4/14.6-V after 20 hrs, error LED flashes) 20 \pm 1 Hours

DETAILED SPECIFICATIONS - VDC Model No. 12248 (con't.)

Absorption mode transitions to Float mode conditions in AGM setting:

Mode: 1) Charging current

2) 5 Hours Time-out: after 5 Hours unit switches to Float Charge Mode

Absorption mode Thermal Runaway Protection: Stops Charging when the second current sample is larger the first current sample (Positive dl/dt)

Switch to Float mode in Bulk charge or Absorption mode when Battery type Button is Pressed For 3 Seconds or longer. **GREEN** Charge - Float LED will blink

Float Charge output Voltage control 13.4@24°C (75°F) ± 0.25 Vdc

Float Charge current control (2A Rate) 1 Adc ± 0.25

(4A Rate) 2 Adc ± 0.25

(8A Rate) 4 Adc ± 0.25

Float charge transitions to PWM Float Charge Mode after 1 Hour

Float Pulse Charge voltage control 13.4@24°C ± 0.25 Vdc

Float Pulse Charge current control: (2A Rate) 1 Adc ± 0.25

(4A Rate) 2 Adc ± 0.25

(8A Rate) 4 Adc ± 0.25

DETAILED SPECIFICATIONS - VDC Model No. 12248 (con't.)

Battery sulphation check period (After absorption charge is finished): 10 minutes

Unloaded output voltage when battery is disconnected: 0.5 Vdc (max.)

Output short-circuit current when battery disconnected: 5mA dc (max.)

Battery flow back current (to the charger) when connected to 12V battery, AC Power disconnected:
30 (max.) mA dc

Maintenance-Float min. allowable voltage: (before restarting Charge mode) 12.5Vdc

All LED indicators will shut off if AC power is disconnected for 5 Minutes

Full time Desulphation output pulse current control $I_{p-p} \pm 3 A_{dc}$

Full time Desulphation output PWM* frequency $100 \pm 10 Hz$

Full time Desulphation duty 0.3%

*Pulse Width Modulated

Temperature Compensation (with ABS-248 Battery Temperature Sensor)

**LED Indicator functions
Tables 5 & 6**

	GREEN	GREEN	GREEN
	GEL	AGM	FLOODED
GEL	ON	OFF	OFF
AGM	OFF	ON	OFF
FLOODED	OFF	OFF	ON

	GREEN	GREEN	GREEN
	2A	4A	8A
2A	ON	OFF	OFF
4A	OFF	ON	OFF
8A	OFF	OFF	ON

DETAILED SPECIFICATIONS - VDC Model No. 12248 (con't.)

Transformer

Transformer Type: Ferrite core transformer

Rising Temperature of Transformer: 80°C Max.

Insulation

Primary to Secondary insulation Test: 1240 Vac 60Hz with 1 minutes, 10mA ac no break down found

Primary to core insulation test: 1240 Vac 60Hz with 1 minutes, 10mA ac no break down found

Secondary to core insulation test: 500 Vac 60Hz with 1 minutes, 10mA ac no break down found

Electrical Cable

Input Lead and plug specifications :CUL SJT 18AWG X2 with UL 2-pin plug, External Length 6 ft

Output lead : 1015 105°C VW-1 16AWG with Trailer connector, External Length 6 ft

Extension cord: 1)1015 105°C VW-1 16AWG with Trailer connector & battery clamp, External Length 24"

2)1015 105°C VW-1 16AWG with Ring terminal & blade type Fuse, External Length 24"

Ring terminal I.D. dimensions Negative 8mm, Positive 10mm

Physical Parameters

Weight: 2.2 lbs.

Plastic enclosure material: UL-94V0 #1 Noryl or #2 PC+ABS #3 PC

Enclosure Dimension: Approx. 5.713 (W) x 5.516 (L) x 2.86 (H) inches

Environmental Characteristics

Operating temperature : -10° to 40°C

Storage temperature : -10° to 80°C

Operating Humidity range: 0 to 95% RH

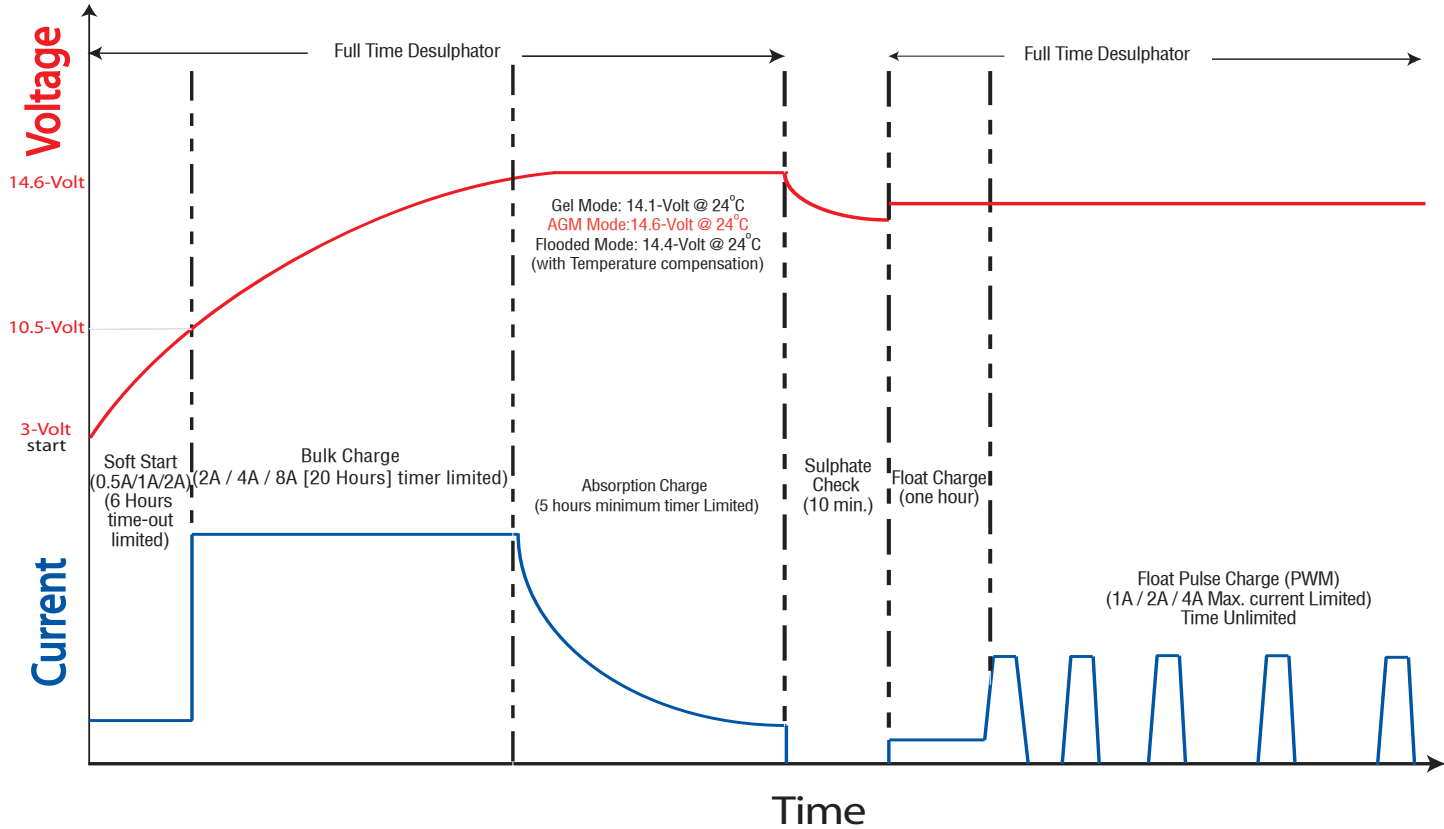

FOR REPAIR OR REPLACEMENT

In the event that you believe your product may be defective, you **MUST** speak to a VDC Electronics technician at 1-800-379-5579 x206 (ET) before proceeding further.

If after speaking with our tech support personnel it is necessary to return the unit, you **MUST** request an RMA number.

All returns must be authorized by VDC Electronics.

Items must be returned within 10 days after receiving your **Return Merchandise Authorization** number and must be packed in the original packaging with manual and all connectors included.

Your Return Merchandise Authorization number must be shown on the return shipping label as follows:

VDC Electronics, Inc.

Returns Department

Attn.: RMA # (Enter Your RMA# Here)

147 D Woodbury Rd.

Huntington, NY 11743

Note: If your questions relate to safety concerns, please contact: customersupport@vdcelectronics.com or if a potentially hazardous emergency may exist cease using the product immediately and call (800) 379-5579 ext. 202 (ET) Monday – Friday or contact our tech support at ext. 206.

Standard operating questions, clearly answered in this manual, will not be answered by phone.

YOUR NOTES:

Guarantee and Warranty

NOTE: ALL returns must be authorized by VDC Electronics after speaking to a VDC Electronics technician at 1-800-379-5579 x206 ET. Please see Page 35 for details.

5 YEAR LIMITED WARRANTY

VDC Electronics, Inc. warrants this product for FIVE years from date of purchase at retail against defective material or workmanship. It will be repaired or replaced at no charge providing it is returned to VDC Electronics, Inc., freight prepaid together with proof of purchase. We make no warranty other than this limited warranty and expressly exclude any implied warranty including any warranty for consequential damages.

(This limited warranty is not transferable)

ONE (1) YEAR 100% UNCONDITIONAL MONEY BACK GUARANTEE:

BatteryMINDer is Guaranteed to perform as claimed or WE will refund your full purchase price, including all taxes, shipping or handling cost applicable to the purchase.

Unit must be returned with Proof of Purchase directly to VDC Electronics, Inc., NOT TO THE DEALER FROM WHICH IT WAS PURCHASED.

