

INSTRUCTION MANUAL

BatteryMINDER® Model 36271*

Maintenance - Charger / Desulfator-Conditioner



***NOT Designed to Replace Original
HIGH-OUTPUT Chargers - Use to
Maintain and Desulfate Lead Acid
Deep-Cycle Battery Systems *After*
Fully Re-Charging **ONLY****

VDC Electronics, Inc.
147 D Woodbury Rd.
Huntington, NY 11743
www.vdcelectronics.com
techsupport@vdcelectronics.com

READ AND SAVE THESE INSTRUCTIONS

TABLE OF CONTENTS

Safety Instructions..... 3

Preparing To Charge..... 5

Charger Location..... 5

DC Connection Precautions..... 6

Qualifying Your Batteries..... 8

Testing a Filler Cap Or Manifold-type Lead Acid Batteries..... 8

Testing With A Hot/Cold Calibrated Hydrometer Tester..... 10

Testing Sealed, Agm Or Gelled-type Lead Acid Batteries..... 10

Unit With Call-outs 12

Simplified Operating Instructions 13

LED Indicator Functions 14, 15

Detailed Operation Instructions 16

Temperature Sensor ABS-248 (At-the-Battery Sensor)..... 17, 21 - 23

Maintaining Multiple Batteries..... 25

Battery Configurations 26

Troubleshooting - Model 36271 27

Detailed Specifications - VDC Model No. 36271..... 29 - 33

Charging Profile..... 34

For Repair Or Replacement..... 35

Guarantee And Warranty..... 36

**Underwriters Laboratories (UL)
REQUIRED SAFETY INSTRUCTIONS
WARNING**

**TO REDUCE THE RISK OF FIRE,
ELECTRIC SHOCK, OR INJURY TO
PERSON, OBSERVE THE FOLLOWING:**

1. Do not expose charger to rain or snow. It is designed to operate ONLY INDOORS.
2. USE of any attachment not specifically recommended by the battery charger manufacturer for use with this exact model of charger may result in risk of fire & electric shock or injury to person.
3. An extension cord should not be used, unless absolutely necessary. Use of an improper extension cord could result in fire or electric shock. If extension cord must be used be sure:
 - a. Pins on plug of extension cord are the same number, size, & shape of plug on charger
 - b. Extension cord is properly wired and in good condition.

c. Wire size is enough for AC ampere of charger as specified below: Length of cord, feet (meters)
25 (7.6), 60 (15.2), 100 (30.5), 150 (45.6) AWG
Size #18.

4. Do not use charger if it received a sharp blow, been dropped, or damaged.
5. Charger contains no serviceable parts. If it fails for any reason, return to the address shown within for a free replacement under warranty.
6. To reduce risk of electric shock, unplug charger from outlet before attempting any cleaning.
7. **WARNING - RISK OF EXPLOSIVE GASES. WHENEVER YOU WORK NEAR A LEAD ACID BATTERY IT IS DANGEROUS. BATTERIES GENERATE EXPLOSIVE GASES DURING NORMAL BATTERY OPERATION. FOR THIS REASON, IT IS OF UTMOST IMPORTANCE THAT EACH TIME BEFORE USING YOUR CHARGER, YOU MUST READ THIS MANUAL AND FOLLOW THE INSTRUCTIONS EXACTLY.**

To reduce risk of battery explosion, follow these instructions and those published by the battery manufacturer and the manufacturer of any equipment you plan to use in the vicinity of the batteries. Review cautionary markings on the products and the engine.

8. **PERSONAL PRECAUTIONS** when working with or near a lead acid battery.

a. Someone should be able to hear your voice or close enough to aid you when working near a lead acid battery.

b. Have fresh water and soap nearby case battery acid contact skin, clothing, or eyes. Wear complete eye protection and clothing protection. Avoid touching eyes while working near batteries.

c. If battery acid does contact skin or clothing, wash immediately with soap and water. If acid entered the eye, immediately flood the eye with running water for at least 10 minutes and get help immediately.

d. NEVER smoke or allow a spark of flame near batteries or engine.

e. Be extra cautious to reduce risk of dropping a metal tool or auto part onto battery. It might spark or short circuit battery or other electrical part that may cause an explosion.

f. Remove personal metal items such as rings, bracelets, necklaces, and watches when working with a lead acid battery. A lead acid battery can produce a short circuit current high enough to weld a ring or the like to metal, causing a severe burn.

g. Charger is designed to be used for recharging lead acid batteries ONLY. Never use it to power a low voltage electrical system, or for attempting to recharge dry cell batteries that are commonly used in house holds. These batteries may explode and cause injury to persons and damage property

NEVER CHARGE A FROZEN BATTERY OR ONE AT A TEMPERATURE ABOVE 123° F.**PREPARING TO CHARGE**

- a. If necessary to remove batteries from equipment to charge. Always remove ground terminal first. Turn off all accessories in the vehicle, so as not to cause an arc.
- b. Be sure area around batteries is well ventilated while batteries are being charged. Force gas vapors away by using a piece of non-metallic material as a fan.
- c. Clean battery terminals. Be careful to keep corrosion from contacting eyes.
- d. Add distilled water to each cell until battery acid reaches level specified by the manufacturer. This helps purge excessive gas from cells. Do not overfill. For a battery without caps, follow manufacturer's recharging instructions.
- e. Study all battery manufacturer's specific instructions such as removing cell caps while charging

and recommended charge rates.

- f. Determine condition of batteries, by referring to instructions herein, before ever attempting to charge or desulfate any / all batteries.

CHARGER LOCATION

- a. Make sure charger is as far away from batteries as output cables permit.
- b. Never place charger directly above batteries being charged; gases from batteries will corrode and damage charger.
- c. Never allow battery acid to drip on charger when reading specific gravity or filling.
- d. Do not operate charger in a closed-in area or restrict ventilation in any way.
- e. Do not set batteries on top of charger.

DC CONNECTION PRECAUTIONS

- a. Connect and disconnect DC output clips from batteries only after removing charger power cord from outlet.
 - b. Attach clips to battery posts and twist or rock back and forth several times to make good contact. This tends to keep clips from slipping off terminals and reduces risk of sparking.
- FOLLOW THESE INSTRUCTIONS WHEN BATTERIES ARE INSTALLED IN EQUIPMENT (VEHICLE, PWC, BOAT, TRACTOR, ETC.) A SPARK NEAR BATTERIES MAY CAUSE BATTERIES TO EXPLODE. TO REDUCE RISK OF A SPARK NEAR BATTERIES:**
- c. Position DC output cord to reduce risk of damage by hood, door, covers, or moving engine parts.
 - d. Stay clear of fan blades, belts, pulleys, and other parts that can cause injuries.
 - e. Check polarity of battery posts. POSITIVE

(POS, P,+) usually has a larger diameter than NEGATIVE -.

f. Determine which post of battery is grounded (connected) to the chassis of equipment. If negative post is grounded see Item N. If positive post is grounded see item P.

N. For negative grounded equipment, connect POSITIVE (**RED**) clip from charger to POSITIVE (POS, P, +) ungrounded post of battery. Connect NEGATIVE (**BLACK**) clip to vehicle chassis or engine block away from batteries. Do not connect clip to carburetor, fuel lines, or metal body parts.

g. For positive ground equipment, connect NEGATIVE (**BLACK**) clip from charger to NEGATIVE (NEG, N,) UNGROUNDED POST OF BATTERY. Connect POSITIVE (**RED**) CLIP to chassis or engine block away from batteries.

**DO NOT CONNECT CLIP TO CARBURETOR,
FUEL LINES, OR SHEET METAL BODY
PARTS.**

Connect to heavy gauge metal part of frame or engine.

h. When disconnecting charger, disconnect charger from AC outlet, then remove clips from vehicle chassis, and battery posts.

Operating instructions for charge information.

**FOLLOW THESE STEPS WHEN BATTERIES
ARE OUTSIDE OF VEHICLE OR EQUIPMENT.
A SPARK NEAR THE BATTERIES MAY CAUSE
BATTERY EXPLOSION. TO REDUCE RISK OF
A SPARK NEAR BATTERIES:**

a. Check polarity of battery posts. POSITIVE (POS,P,+) usually has a large diameter than NEGATIVE (NEG, N, -) battery post.

b. Connect (**RED**) charger clip to (POS+) post of battery.

c. Position yourself and free end of cable as far away from battery as possible, then connect NEGATIVE (**BLACK**) charger clip to free end of cable.

d. Do not face batteries when making final connections.

e. When disconnecting charger, always do so in reverse sequence of connecting procedure and break first connection while as far away from batteries as practical.

**DO NOT ATTEMPT TO PERMANENTLY
INSTALL ANY CHARGER NOT SPECIFICALLY
DESIGNED FOR PERMANENT
INSTALLATION, ESPECIALLY IN A WET /
MARINE ENVIRONMENT**

QUALIFYING YOUR BATTERIES:**Preliminary Requirements**

NOTE: The BatteryMINDer has no electrical output unless it is connected to healthy batteries. Testing the BatteryMINDer with a volt or an Amp meter without the unit being connected across good batteries will result in a false reading. If you experience any problems, or are not sure of how to properly use or connect your BatteryMINDer, please e-mail our technical support at: techsupport@vdcelectronics.com or call our toll-free technical support line 800-379-5579 x206 (Eastern Time). **Be certain to leave your phone number with the area code, time zone and the best time to call.**

To gain the best result from your new charger and to maximize the life and performance of your batteries we strongly recommend you qualify (test) your batteries before attempting to either charge-maintain or desulfate them. Remember, even if you just purchased “new” batteries they may have been subjected to conditions that have caused

“sulfation” such as high temperature ($\geq 80^\circ$).

NOTE: If your batteries are new and you are certain they were not subject to conditions that could have caused sulfation*, even before you purchased them, you can disregard our recommendations for qualifying / testing your batteries, before using the BatteryMINDer.

* Such as high temperature storage ($\geq 80^\circ\text{F}$) and/or allowed to self-discharge to 12.4 Volts or lower (6.2-V for 6-Volt batteries.)

Testing a Filler Cap or Manifold-type Lead Acid Batteries. Set Charger to Flooded Mode.

1. Carefully remove all caps or manifold-type covers from your batteries.
2. Check the water-liquid electrolyte level. If the level is low or has ever been below top of plates, severe lead plate sulfation has taken place. Significant recharge/reconditioning time is needed to restore these plates to a condition where the batteries can be expected to function normally.

3. Refill each cell with distilled water only to the liquid level indicator found in each cell. **Before proceeding further you must be thoroughly familiar with the safety and operating instructions.**

4. Recharge the batteries with the BatteryMINDER to ensure that they are slowly and completely charged before you determine their condition. Allow each battery to “rest”* overnight for a minimum of 12 hours before testing with a temperature compensated hydrometer and/or digital type voltmeter only.

*** “RESTED” = batteries that have been as fully charged as possible, using a 3 stage charger (model 36271) and left disconnected from charger or any type load for a minimum of 12 hours.**

5. If the BatteryMINDER battery condition LED lights (**YELLOW**) within 72 hours or no balls float in one or more cells, battery may be too far gone to be fully desulfated. Reconnect battery to your BatteryMINDER and press the Maintenance mode

button. Allow batteries to remain in maintenance mode for a minimum of 72 hours, before re-test. Use a hot/cold calibrated hydrometer tester for the most accurate results** (see next page) if you see an increase in the Specific Gravity (SG) or voltage indicating that there is an improvement in the battery’s condition, continue desulfating for an additional 72 hours and retest. Continue this process until the SG or voltage readings no longer increase.

Specific Gravity – Capacity

Temp. Compensated Hydrometer - meter or 4 ball type	Full Capacity Percentage
1.270 (4 Balls floating)	100%
1.250 (3 Balls floating)	75%
1.190 (2 Balls floating)	50%
1.150 (1 Balls floating)	25%
1.120 (0 Balls floating) May denote shorted cell or battery that has been severely discharged and may not be recoverable	0%

TABLE 1

Testing with a Hot/Cold Calibrated Hydrometer Tester

Read the tester instructions carefully for most accurate readings.

1. When using the tester the first time or after a long period of non-use, fill the tester with the battery fluid and let it sit for 1/2 hour or longer. This will soak the balls in order to give you more accurate readings. Failure to do so will give you false readings indicating a battery that may not be in as good a condition as you may have thought.
2. After inserting the tester in a cell, gently tap the tester several times against the inside wall of each cell to dislodge air bubbles that will cause more balls to float than should. Failure to do so will yield false readings that indicate a battery that is not fully desulfated or does not qualify for desulfation.
3. If no balls float in any cell, the cell is shorted. This means your battery is beyond the point of being properly recharged or reconditioned-desulfated. Dispose of the battery.

If each cell floats three (3) or more balls (or 1250 on gauge-type), your battery can be desulfated-reconditioned.

4. Always rinse the tester with fresh water after every use. Failure to do so will cause false readings.

Testing Sealed, AGM or Gelled-type Lead Acid Batteries

These batteries have no filler caps or manifold-type covers. Because you cannot gain access to the interior of your battery you cannot test it with a hydrometer.

Testing Using a Digital Voltmeter:

1. Recharge batteries with the BatteryMINDer to ensure they are as completely charged as possible, before you determine its condition. Allow batteries to “rest” (see pg. 9) overnight for a minimum of 12 hours before testing with a digital voltmeter only.

Failure to test “rested” (see pg. 9) batteries will cause false readings. Be certain to read and understand all safety related instructions (pages 3 to 7) before proceeding further.

2. Measure battery voltage, without any load attached. If the voltage is less than 37.2 volts (Typically 50% of charge) the battery may be too heavily sulfated to be fully recoverable. If voltage is 37.2-V or higher full recovery can be expected, given sufficient time (average 1-2 weeks for batteries that are heavily sulfated).

3. Connect the BatteryMINDER to the batteries.

4. Charge batteries to their maximum level. Allow batteries to remain for a minimum of 72 hours before retesting. If improvement is seen, continue until battery voltage reaches full capacity level or no further increase is seen.

OCV=Open Circuit No Load Voltage

OCV - “Rested” Voltage	Full Capacity Percentage
38.7 - 39.3 Volts	100%
37.8 - 38.7 Volts	75%
37.2 - 37.8 Volts	50%
36.6 - 37.2 Volts	25%
36.0 - 36.6 Volts	0%
<33 Volts = shorted	

TABLE 2



- 1) Battery clip cordset w/ qwik connect plug (pgs.13, 16)
- 2) Ring terminal cordset w/ qwik connect plug (pgs. 13, 16)
- 3) Mounting tabs
- 4) Input power cordset (pg. 13, 18)
- 5) Output cord w/ qwik connect plug (pg. 13, 16)
- 6) Temperature sensor input connector (pg. 13, 17, 21)
- 7) n/a
- 8) Battery type selection button (pgs. 13, 17, 18)
- 9) Start / reset / stop selection button (pgs. 13, 17, 18)
- 10) LED indicators for power, connection, fault, battery condition, charge status (pgs.13-15, 18-20, 23)
- 11) Temperature sensor with cord and ring terminal (pgs. 17, 21 - 23)

Simplified Operating Instructions

(Read and thoroughly understand ALL SAFETY Instructions on pages (3-7) and Qualifying Your Batteries pages 8-11, BEFORE proceeding further.

1. Attach a battery connector assembly (supplied) to output cordset of charger, either the clips or ring terminal assembly, - NEVER BOTH at same time. (See diagrams - Page 26)
 2. Attach output to battery terminals-**RED** band =Positive + **BLACK** band = Negative.
2-a: Attach temperature sensor ABS-248 to batteries and then to charger*. (See Page 21)
 3. Plug AC power cord into 120 Vac electrical outlet. Observe REVERSED Polarity LED indicator. If lit **RED**, reverse battery connector attachments on battery.
 4. Observe Battery Connected - Error Indicator, LED Must be lit **GREEN****
- 5. Charger will automatically start in Gel and 2.7 Amp modes when first plugged into 120 Vac power.** Restart and reset to correct modes, if required.
6. Select Correct battery type: Flooded (wet-filler caps or manifold, Sealed AGM (“dry”) or Sealed Gel ***
 7. Observe **GREEN** LED indicator labeled Charge-Float = Solid when charging, Blinking when maintaining batteries.

IF IN DOUBT REGARDING ANY OF THE ABOVE, REFER TO FULL INSTRUCTIONS

* See detailed instructions for need and method of properly connecting sensor to batteries, pgs. 21 - 23.

** See full instructions if not lit **GREEN**.

*** IMPORTANT If in doubt about what type, consult with seller or manufacturer of batteries, before going further. Choosing the wrong setting will cause over or under charge, leading to shortened battery life or generating potentially hazardous hydrogen gas.

LED INDICATOR FUNCTIONS -- Tables 3 (top) and 4 A&B (bottom)

	Battery Condition Indication
Battery connected before charge: $V_b < 33V$	YELLOW
$V_b > 33V$	GREEN
If Reset Button is pressed in the charging stage	MAINTAINS PREVIOUS STATUS
Battery sulfation checked: $V_b < 38.4V$	YELLOW
$V_b > 38.4V$	GREEN

LED Status - (Battery Connect / Error and Charge LEDs)	CONNECT / ERROR		CHARGE - FLOAT
	GREEN	RED	GREEN
A.C. power disconnected, battery connected correctly	OFF		OFF
A.C. power connected, battery connected	GREEN		OFF
A.C. power connected, battery connected (press start button)	GREEN		ON
At Soft Start mode, Bulk charge mode, Absorption mode	GREEN		ON
In Sulfate check mode Float charge mode	GREEN		FLASH
A.C. power connected Reversed Battery Polarity	RED ON		OFF
A.C. power connected, charger output Clip shorted	RED ON		OFF
A.C. power connected, battery voltage is less than 9V	RED ON		OFF
Timed-out when in SoftStart or Bulk mode	RED FLASH		OFF
Timed-out when in Mode A, Mode C, Absorption mode	RED FLASH		FLASH
Absorption mode Thermal Run away	RED FLASH		OFF

LED INDICATOR FUNCTIONS

LED indicators refer to charger label at right

GREEN
2.7A
ON

TABLE 5

	RED	RED	RED
	AGM	Flooded	Gel
AGM	ON	OFF	OFF
Flooded	OFF	ON	OFF
Gel	OFF	OFF	ON

TABLE 6

BatteryMINDER®

**Charger / Maintainer /
Full Time De-Sulfator - Conditioner**

36-Volt @ 2.7 Amp

Model 36271

VDC Electronics, Inc.
800-379-5579 (ET)
www.vdcelectronics.com
U.S. Patents: 5783929 & 6078166

● 2.7 A

● AGM

● FLOODED

● GEL

MAINTENANCE
MODE ONLY
(HOLD 3 SEC.)

PRESS

Select
Battery Type

●

●

●

PRESS

Start / Reset
/ Stop

Green = Battery Connected

ERROR:

Red = Polarity Reversed / Battery = less than 9-Volts*

Red (Blinking) = Battery Fault / Battery Weak*

Battery Condition Indication

Power On & Battery Connected Before Start Charge:

Green = OK - Accepted

Yellow = Weak / Sulphated / Deep Discharge*

After Charge:

Green = Good

Yellow = Sulphated / Weak*

Charge - Float

Green (solid) = Charging

Green (blinking) = Float (maintenance)

*See Instruction Manual

Hold for 5 sec. for full reset

Detailed Operation Instructions Model 36271

After carefully reading and understanding the Safety Instructions contained in this manual (pages 3 to 7) and having evaluated your batteries as described in Qualifying Your Batteries (pages 8 to 10) you are properly prepared to begin using your charger.

1. Attach output cord of charger to either the Battery Clip(s) Assembly (BCA) (supplied) or the Ring Terminal Assembly (RTA) (supplied) depending on your preference. However never use both assemblies at the same time for any reason whatsoever.

Never use either of these assemblies on any other charger or for any other purpose such as improvised “jumper cables”, etc.

Using the RTA on batteries remaining in their normal use location (in same place they are regularly installed will normally prove the safest and most

convenient. If you have several applications you may wish to purchase additional Ring Terminal Assemblies (RTA) available from your dealer or VDC Electronics, Inc. directly.

Note: this assembly contains a 15 Amp automotive type fuse and is replaceable should for any reason it were to blow. Never replace this fuse with any type whose rating is higher than 15 Amps, as seriously harmful results may occur.

2. Identify the positive and negative posts or connections on your batteries, usually clearly designated with the polarity markings of + (positive) and – (negative)*. If you have previously installed the RTA referred to in 1. above, you need only to press the connector plug of the charger’s output cord into the mating plug of the RTA. Push firmly and do not leave any space between them.

*See diagrams on Page 26.

Correct polarity and a good connection will be your reward. Attach the **BCA** to the proper battery posts, clamps or screw terminals, depending on type of battery. **ALWAYS connect the negative (Black) clip to a metal grounding point (Negative ground installations such as most golf cars, modern cars, trucks, boats, RVs, etc.) as far away from battery as possible for maximum safety. Never connect to any type of fuel line.**

Note: Older vehicles or other devices may be ***Positive ground installations*** requiring different connection recommendations. If unfamiliar or unsure which battery type of grounding system you have, check with our Tech Support personnel before proceeding further.

Note: Temperature compensation Sensor Assembly (Part# ABS-248). See pages 21 - 24 for full detailed instructions.

3. Determine the type of battery you wish to

charge. When certain press the **Select Battery Type** button. The most common is the **Flooded** kind, distinguished by removable filler caps or manifold covers (Maintenance-Free) which should not be removed unless specifically allowed by the battery manufacturer. The second most popular is the **Absorbed Glass Mat (AGM)** sealed-valve regulated type. Lastly is the sealed valve regulated **Gel** battery.

Note: If unsure of your battery type, check with the battery seller, manufacturer or our Tech Support before proceeding further. The normal (default) setting of your charger is GEL, as this is the lowest voltage output and thus the one least likely to cause your battery to be overcharged, should you incorrectly select the wrong battery type. However be aware that using the wrong setting for a particular type battery can dramatically shorten its life and/or cause potentially explosive gas to be emitted from the battery.

4. After selecting both battery type and charge rate, plug the unit's Power cord into a standard – grounded 120 Vac electrical outlet. The Battery Connected LED Indicator will light **GREEN**. If it does not light **GREEN** check the outlet to be sure it is functioning. In addition, be sure if outlet is controlled by a switch, no one will accidentally shut off the power to the outlet. Check for correct polarity = (no ERROR **RED** LED Indicator). If ERROR Indicator is lit, reverse the charger's output connections to the batteries.

5. Press the Start / Reset / Stop button. The Charge – Float LED Indicator will light **GREEN**. The charger will now begin charging by first checking the battery to determine its voltage and ability to accept a charge. Should the batteries not have a normal fully discharged voltage (31.5-V minimum) the unit will begin charging in the “Soft-Start” mode to determine if batteries can be

safely charged. If it cannot, the Battery Connected – Error LED will flash **RED** and charging will be stopped. Batteries should be carefully checked under a load by a qualified person before further attempting to charge it.

Note: If the battery system does not have a minimum no load OCV (Open Circuit Voltage) of 33 volts, the ERROR LED will light **RED** and charger will reject batteries.

No further effort should be made to charge this battery with this charger or any charger. Discard this battery, unless it has just been subjected to a long period of continuous discharge under a load such as can occur with leaving lights on or cranking an engine excessively. Allow such a battery to “Rest” for several hours (overnight if possible) before determining if it is defective. Be very suspicious of any 36-V battery system that does not have at least 33-Volts (OCV) before it is recharged. It may well be seriously damaged and unsafe for any type of use or recharge. The unit’s Battery Condition Indication LED will help you determine if batteries are less than 33-

Volts (**YELLOW**) or greater than 33-Volts (**GREEN**)

7. After batteries have been fully charged, the **GREEN** Charge-Float LED Indicator will begin blinking. It will continue to blink indefinitely, unless unit is disconnected from batteries or Start / Reset / Stop button is pressed. Should batteries be unable to be fully charged, the LED will not blink and the **RED** Error LED will blink. Batteries may not be able to be fully charged, may be too large or too deeply discharged to be fully charged in the normal time allowed by charger. If you are certain one or more batteries are not defective, having read and understood completely all of the above concerns and conditions, proceed to restart the charger by pressing and holding the Start/Reset/Stop button for approx. 5 seconds until all LEDs Flash.

If batteries are not defective they should be able to be fully charged after being restarted. After sufficient time has lapsed the **GREEN** charge LED Indicator will blink confirming when / if batteries are now fully charged.

If your questions have already been answered in this manual you can expect a response referring you back to this manual and the specific page(s).

After carefully reading these instructions and Troubleshooting (pgs. 27 - 28) sections, should you still have questions, please e-mail our technical support department at:
techsupport@vdcelectronics.com.

Allow up to 3 business days for a detailed response to your questions. Always identify the model number of the product and revision letter of this manual contained on this page below. Without this information we may not be able to assist you correctly.

INSTRUCTIONS:**TEMPERATURE SENSOR Type: ABS-248
(At-the-Battery Sensor)**

If batteries are being charged or maintained in temperatures as low as 32°F to a high of 125°F this sensor must be used.

Congratulations on purchasing the most advanced charger-maintainer-desulfator conditioner on the market today. Read your manual carefully to understand all of its features.

Your temperature sensing system is made up of two components. The thermal sensor w/ ring terminal and male plug w/ dust cover both shown below with extension cord attached. This cord then attaches directly to the mating female receptacle located on the charger. It can be attached to any one of the batteries.

Do NOT modify by extending or shortening the extension cord.

Attaching the temperature sensor with extension cord (11'-8") to any of the batteries.

Your first choice should be to connect it to the positive (+) or Negative (-) post (clamp or screw) of any one battery. This is the best location to sense the temperature of a battery.

The second choice is to place it as close to a battery as possible. Attachment of the sensor to the side or top of battery is also a possible option, under the right circumstances. Be careful to ensure it will not come loose in service.

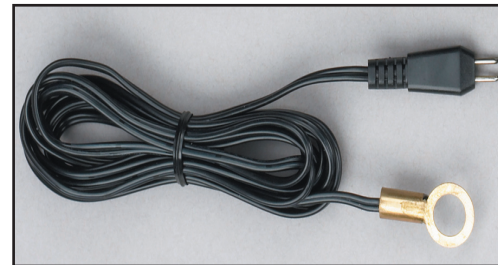

Finally, if placing the sensor on the battery is not practical, place it where the ambient temperature the batteries are exposed to (surrounded by) can be sensed. When properly installed on the battery, your charger is set to provide your batteries with what they need to out-live and out-perform any similar battery used in the same application-conditions, by a factor of two (2).

Temperature has a direct effect on the life of a battery. The design life of a battery is based on an average annual temperature of 25°C (77°F). As the temperature increases above 25°C (77°F), the life of the battery decreases. The chart below shows the effects of temperature.

Effects of Temperature on Battery Life*		
Maximum Annual Average Battery Temperature	Maximum Battery Temperature	Percent Reduction in Battery Life
25°C (77°F)	50°C (122°F)	0%
30°C (86°F)	50°C (122°F)	30%
35°C (95°F)	50°C (122°F)	50%
40°C (104°F)	50°C (122°F)	66%
45°C (113°F)	50°C (122°F)	75%
50°C (122°F)	50°C (122°F)	83%
25°C (77°F)	50°C (122°F)	0%

For example: If a battery’s design life is 10 years at 25°C (77°F), but the average battery temperature is 35°C (95°F), the life of the battery will be only 5 years a 50% decrease.

*GNB Industrial Power, A Division of Exide Technologies, Section 92.30 Part No. Z99-Mar/Sep I&O REV 10/01

The chart below shows the need to regulate the output voltage of the charger to ensure against over or under charging your battery over a wide range of temperatures. Using your At-the-Battery Sensor will accomplish this better than any other known method.

Temperature Ranges	Charge Voltage GEL / Flooded / AGM	Maintenance - Float Voltage		
>=120°F / >=49°C	40.5 / 41.4 / 42.0	38.4	±0.35	Vdc
110-120°F / 43-49°C	40.8 / 41.7 / 42.3	38.7	±0.35	Vdc
100-110°F / 38-43°C	41.1 / 42.0 / 42.6	39.0	±0.35	Vdc
90-100°F / 32-38°C	41.4 / 42.3 / 42.9	39.3	±0.35	Vdc
80-90°F / 27-32°C	42.0 / 42.9 / 43.5	39.6	±0.35	Vdc
70-80°F / 21-27°C	42.3 / 43.2 / 43.8	40.2	±0.35	Vdc
60-70°F / 16-21°C	42.9 / 43.8 / 44.4	40.8	±0.35	Vdc
50-60°F / 10-16°C	43.2 / 44.1 / 44.7	41.1	±0.35	Vdc
40-50°F / 4-10°C	44.1 / 45.0 / 45.6	42.0	±0.35	Vdc
<=40°F / <=4°C	44.4 / 45.3 / 46.2	42.3	±0.35	Vdc

Notes:

MAINTAINING MULTIPLE BATTERIES

BatteryMINDer 36271 maintenance charger Desulfators can be used to **maintain** up to six (6) 6-volt batteries at a time, providing each battery is fully operational (no dead-dying cells), free of sulfate and meeting the minimum full charge “rested” (see pg. 9) voltage of 2.13 volts / cell, after being fully desulfated. Press the Maintenance - Float charge button immediately to ensure BatteryMINDer is in the proper mode for maintenance charging-desulfating, immediately after making proper connection to the batteries. ALL batteries Must be properly tested to ensure they are in good condition (no dead-dying cells or excessive sulfation) before maintaining them in multiples. Only healthy, fully desulfated batteries should ever be MAINTAINED in sets of 2 or more. Test each cell of All filler cap batteries using an accurate, temperature compensated hydrometer. Test sealed (no filler caps) batteries using an accurate, DIGITAL type ONLY, voltmeter. The Minimum

voltage Must not be less than 2.13 volts / cell after fully charging batteries and letting them “Rest*” for 12 hours minimum, before testing. If battery voltage is less than 2.13 / cell you must first desulfate it until you reach a “Rested*” voltage of 2.13 volts / cell.

Only batteries of the SAME type (engine starting or deep cycle (but not together), as well as SAME chemistry-construction such as AGM, Gel, Free Electrolyte (filler caps), Maintenance-Free, etc., should be maintained together. Never mix batteries of different type construction / chemistry, or condition (old with new). ALWAYS test each

(*see pg. 9)

individual battery to be certain it is healthy and free of sulfate before attempting to charge or maintain them, either as a single battery or in sets. NEVER connect multiple batteries together for charging purposes using less than #18 Gauge insulated wire.

Battery Configurations Model 36271 36 Volt @ 2.7A

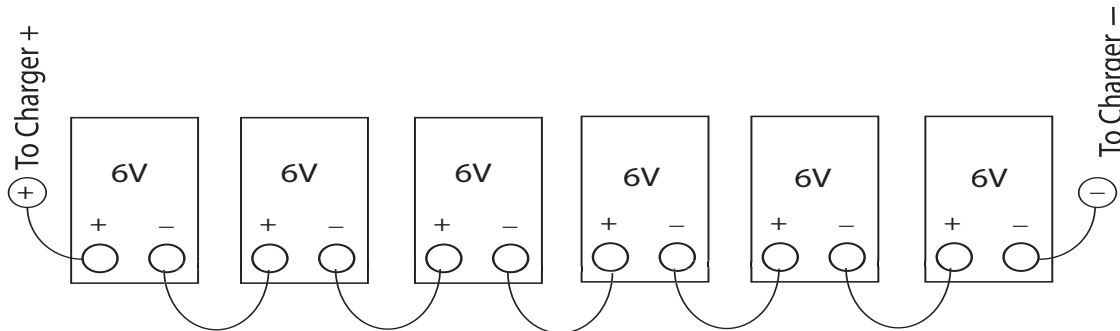
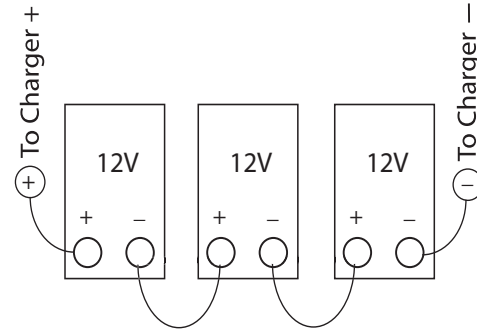

Troubleshooting - Model 36271

NOTE: YOU MUST ALWAYS START WITH FULLY CHARGED BATTERIES BEFORE DETERMINING IF THERE IS A PROBLEM.

We use the word “Indicator” to mean the various LEDs (Light Emitting Diodes) showing the various faults, modes, and conditions of the battery and / or charger.

The words “unit”, “charger” or “recharger” means your model 36271 BatteryMINDer

Problem:

Battery Connect indicator does not light

Solution:

Check electrical outlet. If controlled by a wall switch be sure switch is on and try to prevent accidental shutting it off while charger is working.

Problem:

ERROR indicator lights **RED**
(several possibilities can be the cause)

Solution:

1. Output leads - connections to battery may be reversed. Switch (reverse) connections at battery
2. If still remains **RED** check battery system volt-

age. If 33-Volts or less, one or more batteries may be damaged and should not be recharged. If batteries were just recently removed from a load (headlights, door lights, etc. or vehicle was not used for extended time without a maintenance-charger, allow batteries to “recover” by letting them “rest” without a load. If battery system is healthy and just deeply discharged it should recover voltage (rise above 33 volts) sufficient to allow charger to begin an attempt to fully recharge them. If after batteries have “rested” (see pg. 9) they may not be able to be recovered – recharged. Replace ALL batteries.

Problem:

ERROR Indicator lights **RED** and is **blinking**,

Solution:

1. Batteries may be weak or very heavily sulfated. Allow batteries to remain in Maintenance-Float mode for 72 hours or more and then attempt to recharge again.
2. Batteries may be so large it may require a second full recharge. Repeat recharge by pressing and holding START/RESET/STOP for 5 sec. until ALL LEDs light. Reset battery type, if needed.

Problem:

Battery Condition Indicator lights **YELLOW**
(After battery has been completely charged)

Solution:

Battery still has an unacceptable level of sulfation and must stay connected to charger and remain in Maintenance-Float mode (**GREEN** blinking indicator) for 72 hours or longer. Stop charger by pressing START / RESET / STOP button and observe Indicator. If still **YELLOW** repeat (up to 3 full cycles) or until indicator lights **GREEN**.

Problem:

Battery Condition Indicator lights **YELLOW** (May be several causes)
(Before battery is completely charged)

Solution.

Batteries may be weak due to sulfation, self discharge or was very deeply discharged. Attempt a full recharge and recheck after completion. If still **YELLOW** follow procedure for (After batteries have been completely charged.)

Problem:

Error and Charge LEDs blink simultaneously

Solution:

Charger has timed out before batteries have completely charged. Reset unit. Repeat reset - full recharge by pressing RESET button and holding it down until ALL LEDs flash. Reset battery type, if needed. Press START button to begin full recharge or hold battery type button for 3 secs. or longer to set charger in "maintenance mode."

DETAILED SPECIFICATIONS - VDC Model No. 36271

42.3-V/ 43.2-V/ 43.8-V 2.7Amp MCU controlled H.F. (3) stage Battery Charger w/ Full-Time Desulfation

Note: This equipment has been tested and found to comply with the limits for a Class B digital device, pursuant to part 15 of the FCC Rules. These limits are designed to provide reasonable protection against harmful interference in a residential installation. This equipment generates, uses and can radiate radio frequency energy and, if not installed and used in accordance with the instructions, may cause harmful interference to radio communications. However, there is no guarantee that interference will not occur in a particular installation. If this equipment does cause harmful interference to radio or television reception, which can be determined by turning the equipment off and on, the user is encouraged to try to correct the interference by one of more of the following measures:

- Reorient or relocate the receiving antenna.
- Increase the separation between the equipment and receiver.
- Connect the equipment into an outlet on a circuit different from that to which the receiver is connected.

Electrical Parameters	Unit
Input Voltage :	90-140 Vac
Input Frequency :	47-63 Hz
Unload input current :	100 mA ac
Input Current consumption at 120Vac input, output 39.0V 2.7A loading (In accordance with UL1236)	
Approx:1.8A ac	

DETAILED SPECIFICATIONS - VDC Model No. 36271 (con't.)

Charging Output Control Characteristics

Charging Flow : Battery condition detect> Soft Start Charge>Bulk Charge>Absorption Charge> Sulfate Check>Float Charge

Soft Start Charging Activity conditions: Battery Voltage is over 9-Vdc and less than 31.5-Vdc (charger will start in Gel mode automatically)

Soft Start Charging output current control: 0.7 ± 0.25 Adc

Soft Start Charging Time Limited: (Stops charger if battery cannot be charged over 31.5-V after 6-hours (Error LED flashes) 6 ± 0.25 Hours

Bulk Charging Activity conditions: Starts when Battery Voltage is over 31.5-Vdc (charger will start Gel mode automatically)

Bulk Charging Current control: $2.7 +0.3 / -0$ Adc

Max. rated output voltage and current: 39.0V at 2.7Adc
43.8V at 2.5Adc

Bulk Charging Time Limited: (Stops charger if battery cannot be charged to 42.3 / 43.2 / 43.8-V within 20 hours (Error LED flashes) 20 ± 1 Hours

DETAILED SPECIFICATIONS - VDC Model No. 36271 (con't.)

Absorption Charge mode Output Voltage control: Mode C: 42.3-V (Gel) / 43.2-V (Flooded) / 43.8-V (AGM) @ 24°C ±0.3 Vdc (Selected by pressing Battery type Button)

Absorption mode transit to Float mode conditions:

- 1) Charging Current is less than 25% Bulk Charging current
- 2) 5 Hour Time-out, (after 5 Hours forced to Float Charge)

Absorption mode Thermal Run away Protection: Stops Charging when the second current sample is larger than the first current sample (Positive di/dt)

Transitions to Float mode from Bulk or Absorption charge modes when Battery type Button is pressed and held over 2 seconds

Float Charge output Voltage control 40.2-V @ 24° ±0.3 Vdc

Float Charge current control 1.4 ±0.25 Adc

If power fails in Soft-Start charging stage, unit will return to Soft-Start mode and previous setting, when power is resumed.

If power fails in Bulk charging stage, unit will return to Bulk charging mode and previous setting, when power is resumed.

If power fails in Absorption charging stage, unit will return to Absorption charging mode and previous setting, when power is resumed.

If power fails in float charging stage, unit will return to float charging mode and previous setting, when power is resumed.

Pressing Start/ Reset/ Stop button in charging stage returns settings to previous status

Pressing and holding Start/ Reset/ Stop button (Over 5 seconds) until all LEDs light, returns all settings to original.

DETAILED SPECIFICATIONS - VDC Model No. 36271 (con't.)

Battery sulfation check period (After absorption charge is finished) 10 Minutes

Unloaded output voltage when battery is disconnected : 0.5 (Max.) Vdc

Output short-circuit current when battery is disconnected: 5 (max.) mAdc

Battery flow-back current to charger when connected to

36-V battery w/ AC Power disconnected 30 (max.) mAdc

All LED indicators shut off, If AC power is disconnected after 5 Minutes

Full-time Desulfation output pulse peak current control $I_{p-p} 8 \pm 3 A_{p-p}$

Full-time Desulfation Output- Pulse Width Modulated (PWM) frequency 100 ± 10 Hz

Full-time Desulfation duty 0.3%

**LED Indicator functions
Tables 5 & 6**

GREEN
2.7A
ON

	RED	RED	RED
	GEL	AGM	FLOODED
GEL	ON	OFF	OFF
AGM	OFF	ON	OFF
FLOODED	OFF	OFF	ON

DETAILED SPECIFICATIONS - VDC Model No. 36271 (con't.)

Transformer

Transformer Type: Ferrite core transformer

Rising Temperature of Transformer: 80°C Max. Target is 65°C

Insulation

Primary to Secondary insulation Test: 1240Vac 60Hz with 1 minutes, 10 mA ac no break down found

Primary to core insulation test: 1240Vac 60Hz with 1 minutes, 10 mA ac no break down found

Secondary to core insulation test: 500Vac 60Hz with 1 minutes, 10 mA ac no break down found

Electrical Cable

Input Lead and plug specifications: CUL SJT 18AWG X2 with UL 2 pin plug, External Length 6 ft

Output lead: SPT-2 105°C 18AWG with Trailer connector, External Length 6 ft

Extension cord : 1) SPT-2 105°C 18AWG with Trailer connector & blade type Fuse (7.5A) & battery clamp, External Length 6 ft

2) SPT-2 105°C 18AWG with Ring terminal & blade type Fuse (7.5A), External Length 6 ft

Ring terminal I.D dimensions Negative 8mm, Positive 10mm

Physical Parameters

Plastic enclosure material: UL-94V0 Noryl or PC or PC+ ABS

Enclosure Dimension: Approx 145 (W) x 140 (L) x 58 (H) mm measured without stand

Weight: Approx 1.1Kg

Environmental Characteristics

Operating temperature: -10 to 40°C

Storage temperature: -10 to 80°C

Operating Humidity range: 0 to 95% RH

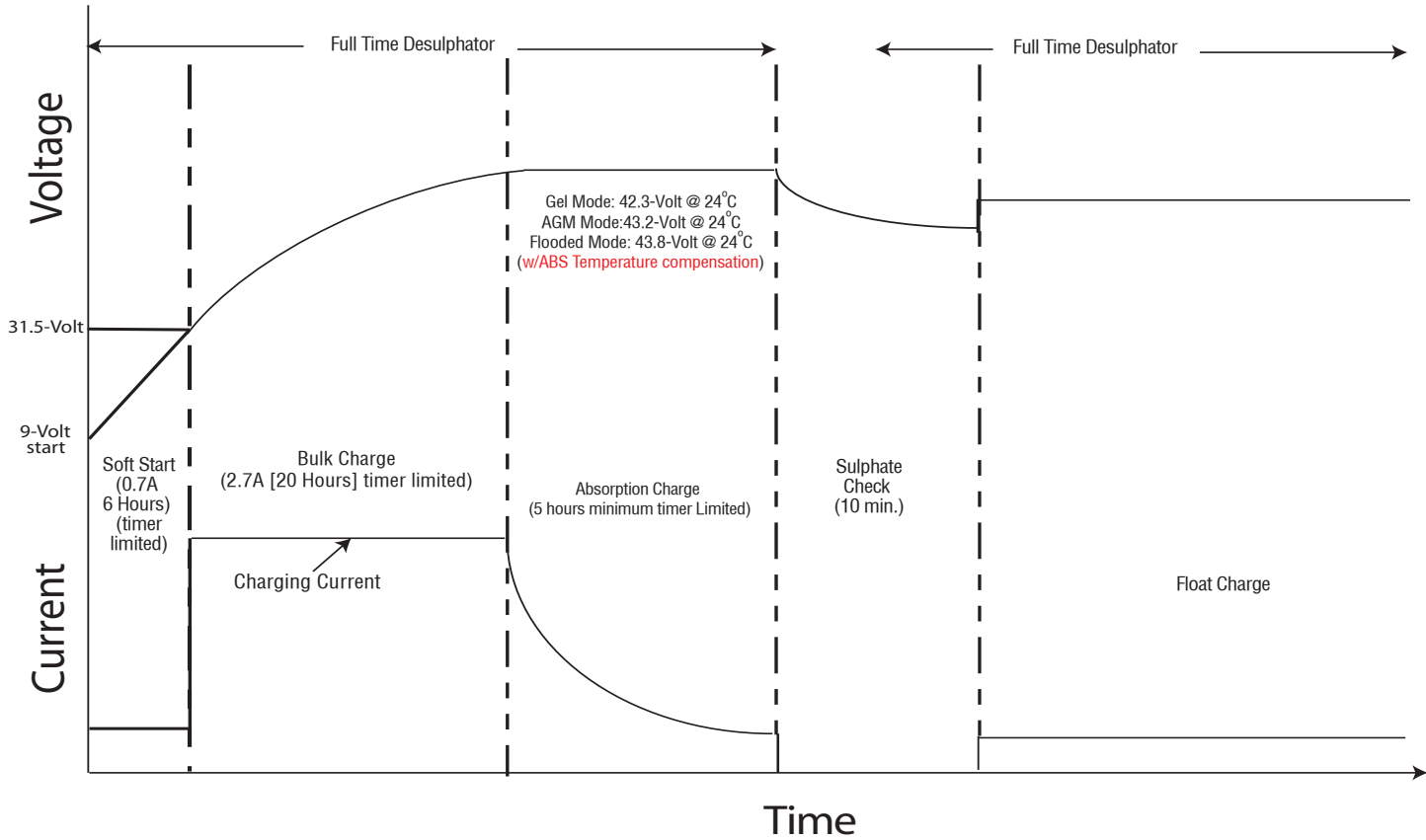

FOR REPAIR OR REPLACEMENT

In the event that you believe your product may be defective, you **MUST** speak to a VDC Electronics technician at 1-800-379-5579 x206 (ET) before proceeding further.

If after speaking with our tech support personnel it is necessary to return the unit, you **MUST** request an RMA number.

All returns must be authorized by VDC Electronics.

Items must be returned within 10 days after receiving your **Return Merchandise Authorization** number and must be packed in the original packaging with manual and all connectors included.

Your Return Merchandise Authorization number must be shown on the return shipping label as follows:

VDC Electronics, Inc.

Returns Department

Attn.: RMA # (Enter Your RMA# Here)

147 D Woodbury Rd.

Huntington, NY 11743

Note: If your questions relate to safety concerns, please contact:

customersupport@vdcelectronics.com or if a potentially hazardous emergency may exist cease using the product immediately and call (800) 379-5579 ext. 202 (ET) Monday – Friday or contact our tech support at ext. 206.

Standard operating questions, clearly answered in this manual, will not be answered by phone.

YOUR NOTES:

Guarantee and Warranty

NOTE: ALL returns must be authorized by VDC Electronics after speaking to a VDC Electronics technician at 1-800-379-5579 x206 ET. Please see Page 35 for details.

5 YEAR LIMITED WARRANTY

VDC Electronics, Inc. warrants this product for FIVE years from date of purchase at retail against defective material or workmanship. It will be repaired or replaced at no charge providing it is returned to VDC Electronics, Inc., freight prepaid together with proof of purchase. We make no warranty other than this limited warranty and expressly exclude any implied warranty including any warranty for consequential damages.

(This limited warranty is not transferable)

ONE (1) YEAR 100% UNCONDITIONAL MONEY BACK GUARANTEE:

BatteryMINDer is Guaranteed to perform as claimed or WE will refund your full purchase price, including all taxes, shipping or handling cost applicable to the purchase.

Unit must be returned with Proof of Purchase directly to VDC Electronics, Inc., NOT TO THE DEALER FROM WHICH IT WAS PURCHASED.

