



FREE to Download



# BATTERY FUEL GAUGE



PN: 70362  
Rev: 080624

## Installation and Operating Instructions

*Instructions importantes concernant la sécurité*

### Manual for the following model(s):

**BFGWOV12V(CT), BFGWOV24V(CT), BFGWOV36V(CT), BFGWOV48V(CT),  
BFGWOV64V(CT), BFGWOV72V(CT)**

**BFGWOVR12V(V)(CT), BFGWOVR24V(V)(CT), BFGWOVR36V(V)(CT),  
BFGWOVR48V(V)(CT), BFGWOVR64V(V)(CT), BFGWOVR72V(V)(CT)**

*\*NOTE: (V) = Optional Vertical Configuration; (CT) = Optional Current Transducer Configuration*

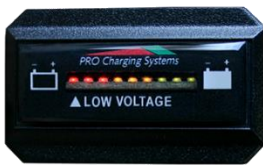

PRO CHARGING SYSTEMS, LLC  
1551 Heil Quaker Boulevard  
LaVergne, TN 37086-3539

For additional information, please call our Technical Support Group at 615.471.5300  
Or email us at [tech@pcsdv.com](mailto:tech@pcsdv.com)

## IMPORTANT NOTICE:

Please save and read these safety, operating, and installation instructions before installing or using your Pro Charging Systems (PCS) product. Contact technical support at PCS with any product, installation, or service questions (615.471.5300).

**Pro Charging Systems has been providing the most advanced chargers on the market since 1989.**

Pro Charging Systems is the industry leader in the development and manufacture of advanced charging and energy management technology. In the beginning, the company developed a line of marine battery chargers under the Dual Pro name to meet the needs of the marketplace. The Dual Pro line of products realized significant success and was widely recognized across the boating industry as the most innovative and durable charger on the market. Today, the Dual Pro line of marine chargers continues to lead the marine market as a result of a commitment to continuous improvement and innovation.

Beyond the marine market, the company also recognized the need for more advanced chargers with more robust capabilities to serve other industry segments including golf carts, electric powered low speed vehicles, industrial equipment, electric lifts, and other segments. The company has and continues to leverage its considerable engineering and technical expertise to design and manufacture battery chargers and energy management systems to provide clients with best-in-class battery charging systems in the world.

**Importantly, Pro Charging Systems is proud to engineer, develop, source, and manufacture the great majority of its products in the United States.**

## TABLE OF CONTENTS

<b>Model Configurations</b>	Page 2
<b>Important Safety Instructions</b>	Page 3 – 7
<b>PROView Link Operation</b>	Page 8 – 10
<b>Installation Guide</b>	Page 11 – 12
<b>LED Indications</b>	Page 13 – 14
<b>Lithium Operation</b>	Page 15
<b>Series vs. Parallel Wiring</b>	Page 16
<b>Troubleshooting</b>	Page 17-19
<b>Housing Drawings</b>	Page 20
<b>Three Wire BFG Wiring Instructions</b>	Page 21
<b>Limited Warranty Information</b>	Page 22
<b>Additional Products</b>	Page 23

<b>Model</b>	<b>Configuration</b>
<b>BFG 12V</b>	12V System – (1) 12V Battery, (2) 6V Batteries
<b>BFG 24V</b>	24V System – (2) 12V Batteries, (4) 6V Batteries
<b>BFG 36V</b>	36V System – (3) 12V Batteries, (6) 6V Batteries
<b>BFG 48V</b>	48V System – (4) 12V Batteries, (8) 6V Batteries, (6) 8V Batteries
<b>BFG 64V</b>	64V System – (8) 8V Batteries
<b>BFG 72V</b>	72V System – (6) 12V Battery, (12) 6V Batteries, (9) 8V Batteries

\* Please see page 20 for mounting hole template and housing size/weight specifications\*

# IMPORTANT SAFETY INSTRUCTIONS

## INSTRUCTIONS IMPORTANTES CONCERNANT LA SÉCURITÉ

**SAVE THESE INSTRUCTIONS.** This manual contains important safety and operating instructions for future reference.

*CONSERVER CES INSTRUCTIONS. CE MANUEL CONTIENT DES INSTRUCTIONS IMPORTANTES CONCERNANT LA SÉCURITÉ ET LE FONCTIONNEMENT.*

**Understand and relate the Hazard Levels and Signal Words utilized in this manual with the following definitions:**



This symbol means: Immediate hazards, which will result in severe personal injury or death.



This symbol means: Hazards or unsafe practices, which could result in severe personal injury or death.



This symbol means: Hazards or unsafe practices, which may result in minor personal injury, product, or property damage.



This symbol means **BE ALERT!** Your safety, or the safety of others, is involved!

## **PERSONAL SAFETY PRECAUTIONS (if applicable to device being operated)**



**Always read all instructions before using your PCS product!**

1. **Wear complete eye protection and clothing protection.** Avoid touching eyes while working near battery. Have plenty of fresh water and soap nearby in case battery acid contacts skin, clothing, eyes, or other surfaces. If battery acid contacts skin or clothing, wash immediately with soap and water. If acid enters eye, immediately flood eye with running cold water for at least 10 minutes and seek medical attention promptly.
2. **Dress properly.** Wear protective, electrically nonconductive clothes, and nonskid footwear. Remove personal metal items such as rings, bracelets, necklaces, and watches when working with a lead-acid battery. A lead-acid battery can produce a short-circuit current high enough to weld a ring or the like to metal, causing a severe burn. Wear restrictive hair covering to contain long hair.
3. **Avoid working alone.** Be sure someone is within range of your voice or close enough to come to your aid when you work near a lead-acid battery.
4. **Stay alert.** Watch what you are doing and use common sense. Do not operate any PCS product when you are tired.
5. **Keep children away.** Children must never be allowed in the work area. Do not let them handle machines, tools, battery chargers, or extension cords.
6. **Keep work area clean.** Cluttered areas invite injuries.
7. **Observe work area conditions.** NEVER smoke or allow a spark or flame in the vicinity of battery or engine. Don't expose to rain. Keep work area well lit.

# IMPORTANT SAFETY INSTRUCTIONS

8. **Do not overreach.** Keep proper footing and balance at all times. Do not reach over or across electrical cables or frames.
9. **Avoid electrical shock.** To reduce risk of electrical shock, unplug charger from outlet before attempting any maintenance or cleaning.
10. **Do not operate PCS product with damaged electrical cord or plug.** To reduce risk of damage to the electrical plug and cord, pull by plug rather than by the cord when disconnecting charger. If damaged, replace the electrical cord or plug immediately.
11. **Store idle equipment.** When not in use, store equipment in a dry location to inhibit rust. Always lock up tools and equipment and keep out of reach of children.
12. **Maintain PCS product with care.** Inspect periodically and, if it has received a sharp blow, been dropped, or otherwise damaged in any way, have it repaired by an authorized technician. Do not disassemble charger; contact PCS technical support when service or repair is required (800.742.2740). Incorrect reassembly may result in risk of electrical shock or fire.
13. **Check for damaged parts.** Before using any PCS product, carefully check any part that appears damaged to determine that it will operate properly and perform its intended function. Check for broken parts and any other condition that may affect proper operation. Any part that is damaged should be properly repaired or replaced by a qualified technician. Do not use the charger if any part does not operate properly.
14. **Replacement parts and accessories.** When maintaining, only use accessories intended for use with this PCS product. Approved accessories are available from Pro Charging Systems (800.742.2740).
15. **CAUTION:** To reduce the risk of fire, use only on circuits provided with 15 amperes branch circuit protection at 100 VAC and 115 VAC and 10 amperes branch circuit protection at 230 VAC in accordance with the national electrical code, ANSI/NFPA 70  
**ATTENTION:** Pour réduire le risque d'incendie, utilisez uniquement sur les circuits munis d'une protection de circuit 15 ampères de branche à 100 VAC et 115 VAC et protection de circuit 10 ampères de branche à 230 VAC en conformité avec le Code canadien de l'électricité CEC Partie 1

## SAVE THESE INSTRUCTIONS!

### INSTALLATION AND PREPARATION (if applicable to device being operated)

**Important note:** If the PCS charger has a model number containing the letters OB, it not intended to be used as a stationary device.



To reduce risk of battery explosion, follow these instructions, those published by the battery manufacturer, and by the manufacturer of any equipment that you intend to use in the vicinity of battery. Review all cautionary markings on these products and on the engine.

*Pour réduire le risque d'explosion, lire ces instructions et celles qui figurent sur la batterie.*

If it is necessary to relocate the battery for charging, first remove the grounded terminal from the battery. Then make sure all accessories are off, so as not to cause battery arcing.

# IMPORTANT SAFETY INSTRUCTIONS



## **RISK OF EXPLOSIVE GASES: WORKING IN THE VICINITY OF A LEAD-ACID BATTERY IS DANGEROUS.**

**Batteries generate explosive gases during normal battery operation. For this reason, it is of utmost importance that prior to each use of your charger, you read this manual and follow the instructions exactly.**

*Il est dangereux de travailler a proximité d'une batterie au plomb. Les batteries produisent des gaz explosifs en service normal. Il est aussi important de toujours relire les instructions avant d'utiliser le chargeur et de les suivre à la lettre.*

**Do not operate charger in a closed-in area or restrict ventilation in any way.**

***Ne pas faire fonctionner le chargeur dans un espace close et/ou ne pas gêner la ventilation.***

Clean battery terminals. Be careful to keep corrosion from coming into contact with eyes. Add distilled water to each cell until battery acid reaches level specified by battery manufacturer. This helps purge excessive gas from cells. Do not overfill. For a battery without cell caps, carefully follow manufacturer's recharging instructions. Study all battery manufacturers' specific precautions such as removing or not removing cell caps while charging and recommended rates of charge.

When using an extension cord, make sure:

- that pins on plug of extension cord are the same number, size, and shape as those of the charger's plug;
- that extension cord meets UL (Underwriters Laboratories, Inc.) acceptance;
- that wire size is large enough for AC ampere rating of unit.



**Always make your extension cord connection on the charger side before connecting to a nearby 120VAC GFCI protected (Ground Fault Circuit Interrupt) outlet. Failure to use a GFCI outlet may result in electrical shock.**

**Note: U(Universal) chargers should be connected to a 110, 115 or 230VAC GFCI protected outlet. The DC connection should always be made before connecting or disconnecting the AC side.**

Note: Extension cords should be industrial grade/heavy duty UL approved and grounded. Check extension cord before use for damage, bent prongs, and cuts. Replace if damaged. Connect the extension cord to the charger; then proceed to plug the extension cord to the GFCI protected (Ground Fault Circuit Interrupt) outlet. Always remove the extension cord from the GFCI protected outlet first when charging is completed, followed by unplugging the charger.

## **GENERAL OPERATION (if applicable to device being operated)**



**Use charger for charging a LEAD-ACID (lead acid, sealed lead acid, gel cell and AGM) battery only. It is not intended to supply power to a low voltage electrical system other than in a starter-motor application. Do not use battery charger for charging dry-cell batteries that are commonly used with home appliances. These batteries may burst, causing personal injury and damage to property.**

*Utiliser le chargeur pour charger une batterie au plomb uniquement. Ce chargeur n'est pas conçu pour alimenter un réseau électrique très basse tension ni pour charger des piles sèches. Le fait d'utiliser le chargeur des piles sèches pourrait entraîner l'éclatement des piles et causer des blessures ou des dommages.*

# IMPORTANT SAFETY INSTRUCTIONS



**WARNING** DO NOT attempt to attach a charger to a battery pack if the output of the charger does not match the battery pack voltage. Example: Model i-3625 is a 36-volt output charger and is only usable on 36 volts battery systems. NEVER connect to just one battery (i.e. 6V) in the pack. Damage can occur.



**WARNING** Be extra cautious to reduce risk of dropping a metal tool onto battery. It might cause a spark or short-circuit a battery or other electrical part, possibly resulting in an explosion. If damaged, contact PCS 800.742.2740).



**CAUTION** NEVER charge a frozen battery. *Ne jamais charger une batterie gelée.* Ensure that the area around your charger and batteries is properly ventilated. Connect your extension cord, with no AC Power present, to the battery charger and proceed to plug your extension cord into a 120VAC GFCI protected (Ground Fault Circuit Interrupt) outlet.



**DANGER** Risk of electrical shock! Do not touch uninsulated parts of the battery charger output connector, battery connector, or battery terminals. Once you plug in your PCS battery charging system, the charge cycle will begin automatically. State of charge will be displayed by illumination of the Light Emitting Diodes (LEDS) on the battery status indicator located on the front of the unit.



**WARNING** DO NOT connect or disconnect the DC output electrical cord to or from the battery receptacle when the charger is on. Arcing and / or burning of the plug and receptacle could result and could cause the batteries to explode. If the charger must be stopped, first disconnect the AC power supply cord from its outlet, then disconnect the charger DC output plug from the battery receptacle. We recommend that you leave your system plugged in. This will reduce sulfation on the lead plates of the batteries and allow your PCS charging system to keep your batteries fully maintained and ready to perform at their best.



**CAUTION** To reduce the risk of fire, use only on circuits provided with 15Amperes Branch Circuit Protection in accordance with the National Electrical Code, ANSI/NFPA 70.



**CAUTION** Study all battery manufacturers' specific precautions such as removing or not removing cell caps while charging and recommended rates of charge. *Prendre connaissance des mesures de précaution spécifiés par le fabricant de la batterie, p. ex., vérifier s'il faut enlever les bouchons des cellules lors du chargement de la batterie, et les taux de chargement recommandés.*



**CAUTION** Never place the charger directly above or below the battery being charged; gases or fluids from the battery will corrode and damage the charger. Locate the charger as far away from the battery as DC cables permit.

*Ne jamais placer le chargeur directement sous la batterie à charger ou au-dessus de cette dernière. Les gaz ou les fluides qui s'échappent de la batterie peuvent entraîner la corrosion du chargeur ou l'endommager. Placer le chargeur aussi loin de la batterie que les câbles c.c. le permettent.*

# IMPORTANT SAFETY INSTRUCTIONS



## CAUTION

If it is necessary to remove battery from vehicle to charge it, always remove grounded terminal from battery first. Make sure all accessories in the vehicle are off in order to prevent an arc.

*S'il est nécessaire de retirer la batterie du véhicule pour la charger, toujours d'ébrancher la borne de mise à la masse en premier. S'assurer que le courant aux accessoires du véhicule est coupé afin d'éviter la formation d'un arc.*



## CAUTION

Never smoke or allow an open spark or flame in the vicinity of the BATTERY the battery or engine.

*Ne jamais fumer près de la batterie ou du moteur et éviter toute étincelle ou flamme nue à proximité de ces derniers.*



## CAUTION

Working in the vicinity of a lead-acid battery is dangerous. Batteries generate explosive gases during normal operation. For this reason, it is of the utmost importance that prior to each use of your charger, you

**read and follow the instructions provided exactly.**

*Il est dangereux de travailler à proximité d'une batterie au plomb. Les batteries produisent des gaz explosifs en service normal. Il est aussi important de toujours relire les instructions avant d'utiliser le chargeur et de les suivre à la lettre.*

# REALTIME SCREEN

PROView Link **Realtime Screen** Provides Live Information About Your Battery Pack

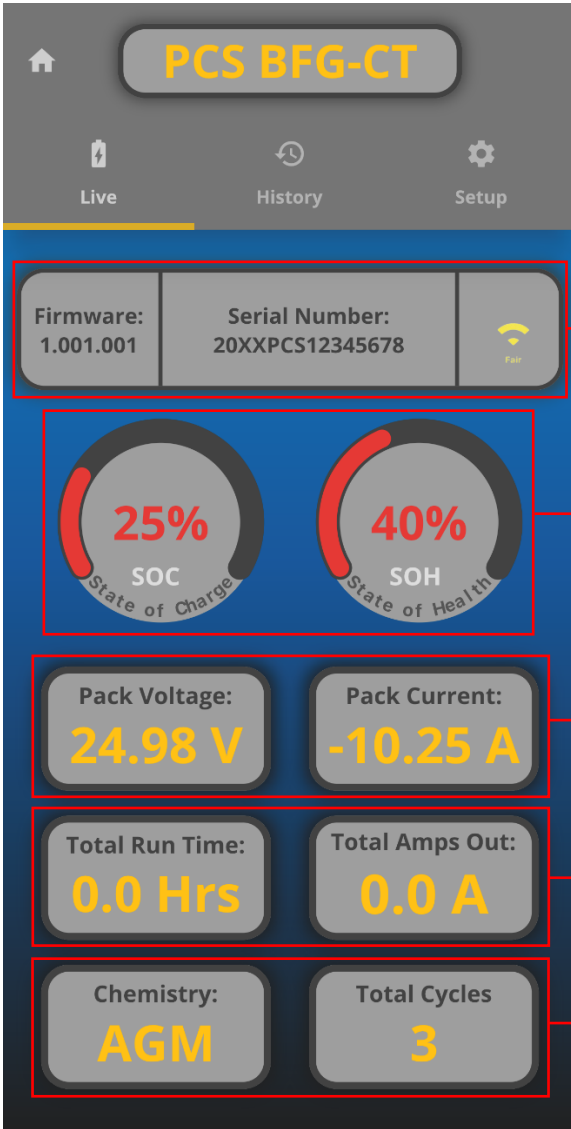

PROView™  
LINK

FREE to Download



Current Unit Firmware Version, Serial Number, and Signal Strength

Battery Pack State of Charge (SOC) & State of Health (SOH)

Live Pack Voltage and Pack Current

Total Run Time and Total Amps Out

Battery Chemistry and Total Cycles

# CYCLE HISTORY

PROView Link Cycle History Tab Provides Detailed Charge/Discharge History of the Pack

**\*NOTE:** This tab is only applicable for BFG's with CT



FREE to Download



PCS BFG-CT

Live History Setup

Export History

#3

<b>Discharge Started:</b> Mar 02, 2021 3:35 PM	<b>Charge Started:</b> Mar 02, 2021 3:35 PM
Run time: 5h 58m	Charge time: 12h 32m
Amps Removed: 23.0 Ah	Amps Replaced: 25.0 Ah

Time Between Charges: 0D 12h 34m

#2

<b>Discharge Started:</b> Mar 02, 2021 3:35 PM	<b>Charge Started:</b> Mar 02, 2021 3:35 PM
Run time: 5h 58m	Charge time: 12h 32m
Amps Removed: 23.0 Ah	Amps Replaced: 25.0 Ah

Time Between Charges: 0D 12h 34m

#1

<b>Discharge Started:</b> Mar 02, 2021 3:35 PM	<b>Charge Started:</b> Mar 02, 2021 3:35 PM
Run time: 5h 58m	Charge time: 12h 32m
Amps Removed: 23.0 Ah	Amps Replaced: 25.0 Ah

**CSV Export:** Export Cycle History to an Excel (.csv or .xlsx) File and Email It or Save The File to Your Device

**Run Time:** Total Time the Battery Pack Was Used During Given Discharge Cycle

**Charge Time:** Total Time Elapsed During Given Charge Cycle

**Amps Removed:** Capacity in Ah Taken Out of Battery Pack During Given Discharge Cycle.

**Amps Replaced:** Capacity in Ah Put Back into the Battery Pack During Given Charge Cycle.

# FUEL GAUGE SETUP

PROView Link **Setup Tab** Allows for Full Gauge Customization



PROView™  
LINK

FREE to Download



Rename Your Device -  
Maximum 11 Characters

Set Chemistry and Amp Hour to  
Allow for Most Accurate State of  
Charge and State of Health

Change LED Brightness to Suit Any  
Situation: Lower to Conserve Power  
or Higher for Bright/Sunny  
Environments

Reset Cycle History When Installing  
New Battery Pack

Assign Asset ID, Group Code, Description,  
and Customer ID to Your Unit for Further  
Asset Tracking/Management

Recalibrate Current Transducer Upon  
Replacement

# INSTALLATION GUIDE

**Step 1:** After determining the location for the Gauge, drill the necessary holes to allow for installation and feed the wiring to the battery area.

**Step 2:** Check the battery pack with a DC voltmeter to determine which two posts provide entire battery pack voltage.

**Step 3:** The cable leading from the battery pack to the Battery Fuel Gauge comes in two parts. Connect the part with the ring terminals to the batteries first. (see below)

**Step 4:** After confirming that the connections to the battery pack are correct, “mate” that cable with the cable that comes from the gauge using the JST Connector Tab and housing that are already attached to the cables.

**\*NOTE:** If installing a Battery Fuel Gauge with a Current Transducer (CT), please see the next page on how to install the CT on your battery pack.

## Proper Order of Connections:

**A** – GREEN CONDUCTOR TO BATTERY PACK’S MOST POSITIVE TERMINAL (+)

**B** – BLACK CONDUCTOR TO BATTERY PACK’S NEGATIVE MOST GROUND TERMINAL (-)

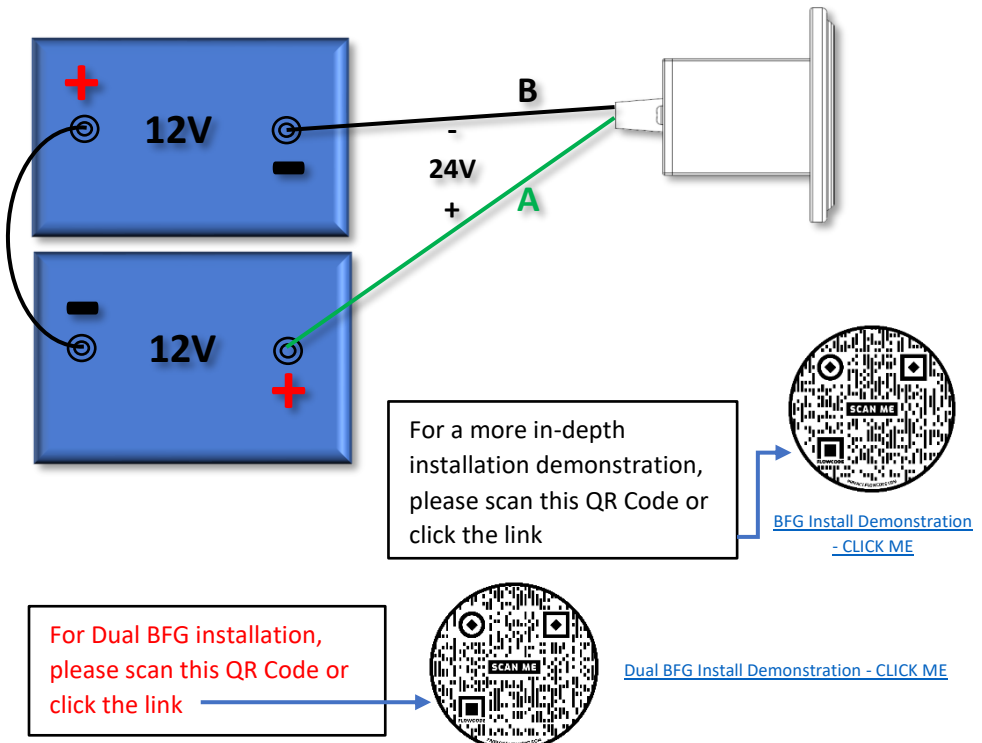

# CT INSTALLATION GUIDE

## IMPORTANT:

1. The Current Transducer (CT) measures charging AND discharging current. For the readings to display properly, it is imperative that the orientation of the CT is correct.
2. See diagrams below for orientation of CT arrow within battery pack.
3. To confirm operation, please download the PROView Link App (available for iOS and Android). This will allow the user to see real-time data streaming from the device.
4. Battery current will display as negative when discharging and positive when charging the batteries. If this is not the case, simply reverse the orientation of the CT.

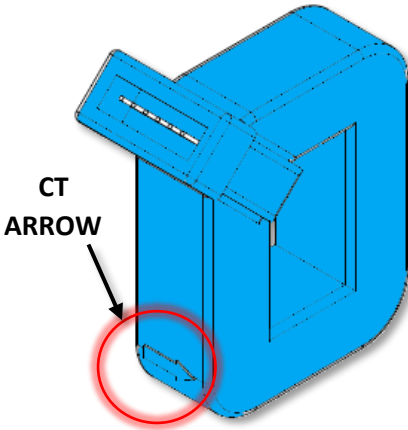

[CT Install Demonstration - CLICK ME](#)

For a more in-depth CT installation demonstration, please scan this QR Code

If you are installing a Battery Fuel Gauge with CT and are using a PCS SS/PS or any multibank charger, please scan this QR Code



[Multibank Charger with BFG CT Install - CLICK ME](#)

## MULTI-BATTERY SETUP:

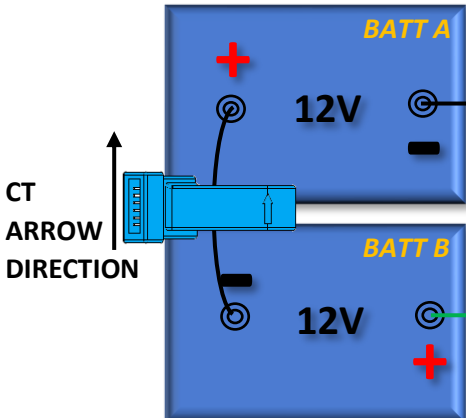

The jumper between **BATT A** & **BATT B** must be fed through the CT.

### Current Flow Path:

**BATT B (+) → BATT B (-) → BATT A (+) → BATT A (-)**

The **BLUE** arrow above is where the CT would be placed in the pack, with the CT arrow facing the same direction as the above **BLUE** arrow.

This can be applied to all setups where jumpers are used for connections within a pack no matter the number of batteries.

# FUEL GAUGE INDICATIONS

The PCS Battery Fuel Gauge (BFG) uses a total of (9) LED indicators in order to display the State of Charge of the battery pack.

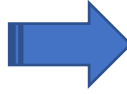

LED	COLOR	APPROXIMATE STATE OF CHARGE(SOC)
9 <sup>th</sup>	GREEN	>= 90%
8 <sup>th</sup>	GREEN	>= 80%
7 <sup>th</sup>	GREEN	>= 70%
6 <sup>th</sup>	AMBER	>= 60%
5 <sup>th</sup>	AMBER	>= 50%
4 <sup>th</sup>	AMBER	>= 40%
3 <sup>rd</sup>	RED	>= 30%
2 <sup>nd</sup>	RED	>= 20%
1 <sup>st</sup>	RED	>= 10%

## SPECIAL NOTES:

- There is some degree of delay within the LED indications to ensure that the reported State of Charge is accurate, therefore the State of Charge reported within the app may not always immediately match the LED indications.

# FUEL GAUGE INDICATIONS

- *The LEDs will stay on when the equipment is in use. When the equipment/vehicle is not being used, the Battery Fuel Gauge will go into **LOW POWER MODE**. This mode will flash the LED corresponding to the State of Charge every few seconds to conserve power.*
- *During charge, the indicator will scroll from the 1<sup>st</sup> LED up to the LED corresponding to the State of Charge. This may not always happen when the charger is initially plugged in but should scroll once battery pack is at least 50% charged.*
- **FLASHING 1<sup>st</sup> LED** – *This represents Low Voltage LED and will blink when the battery pack voltage reaches a very low level (approx. 1.8 Volts/Cell). ie- on a 48V battery pack, the voltage would be 43.20V.*
- *If the Low Voltage LED comes on often or becomes solid, it is recommended that use of the equipment be stopped immediately to protect electronics that are connected to the battery pack. Recharge batteries as soon as possible.*
- **IMPORTANT:** *The BFG with CT has a current draw of  $\approx 25\text{mA}$  (MAX) during normal operation and factory LED intensity.*

# LITHIUM APPLICATIONS

A PCS Battery Fuel Gauge (BFG) configured for Lithium will need to calibrate to the battery pack before a State of Charge can be displayed.

*This calibration process is as follows...*



1. The three **AMBER** LEDs will slowly pulse in and out once the gauge is initially attached to the battery pack.
2. At this point, please open the **PROView Link App** on your mobile device and connect to your Battery Fuel Gauge. Please navigate to the “**Setup**” tab (see page 10). There are three **critical** settings to ensure proper Lithium Gauge operation. The battery **Chemistry** must be set to Lithium. The **Ah Capacity** must be set equal to total battery pack capacity (see next page). **IF** there is a selection for setting battery voltage, the **Voltage** must be set equal to total battery pack voltage (see next page).
3. Once these steps are complete, the Battery Fuel Gauge will begin to look for a full charge on the battery pack. Once the gauge detects a full charge, the pulsing amber LEDs will cease, and all 9 LED indicators should be illuminated with the PROView Link app reporting 100% SOC.
4. If the gauge continues to show pulsing **AMBER** LEDs after a charge cycle has completed, please see page 12 of this manual for instructions on how to install the current transducer. To ensure the current transducer is installed correctly, please navigate to the “**Live**” tab in the **PROView Link App** (see page 8). Look for the “**Pack Current:**” box. When your battery charger is plugged in and charging, the number displayed should be a positive number. When your batteries are being used, the number displayed should be a negative number.
5. If the Battery Fuel Gauge is ever disconnected from the battery pack, either by physically removing the connections or the battery shutting itself off for whatever reason, the above calibration process must be repeated.
6. If you are experiencing issues with setup or operation, please contact PCS Support:

PRO CHARGING SYSTEMS, LLC  
1551 Heil Quaker Boulevard  
LaVergne, TN 37086-3539

For additional information, please call our Technical Support Group at 800.742.2740  
Or email us at [tech@pcsdv.com](mailto:tech@pcsdv.com)

# SERIES VS. PARALLEL WIRING

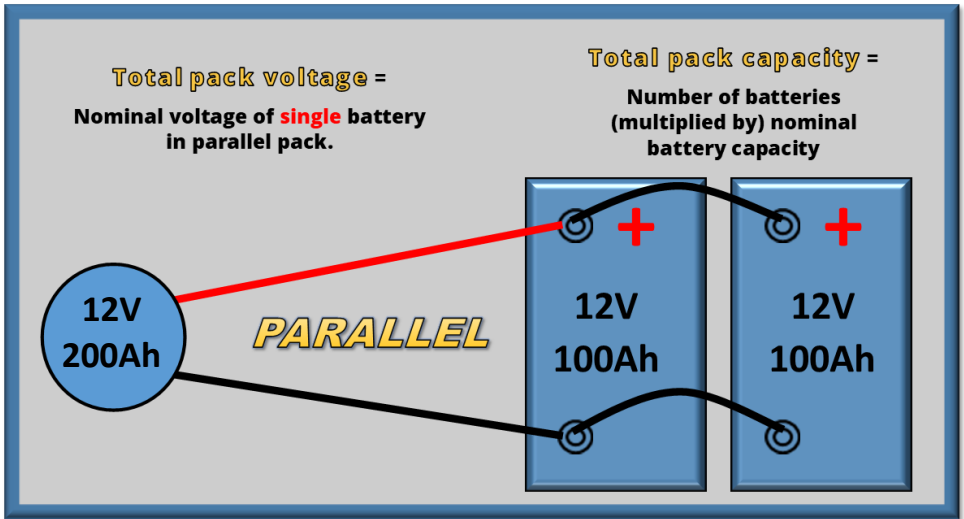
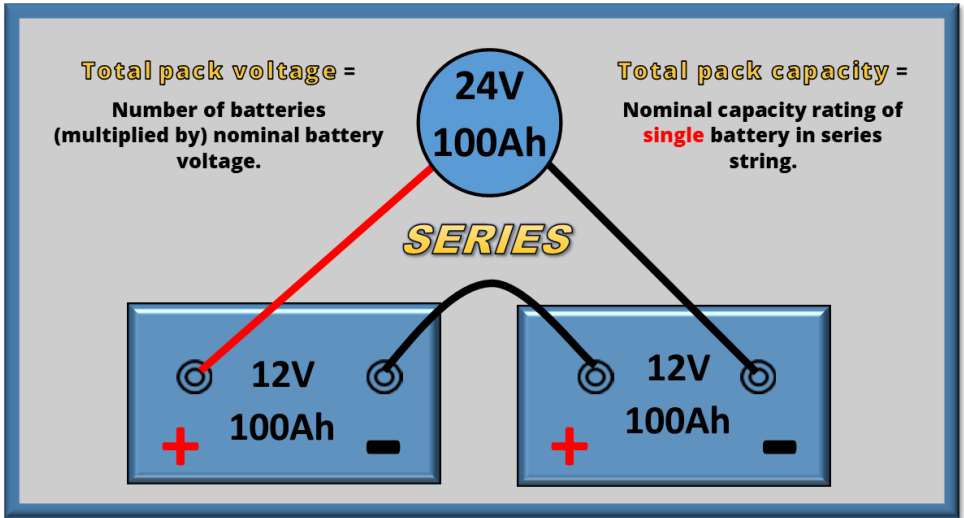

# TROUBLESHOOTING

**PROBLEM: The LED indicator illuminated on the Battery Fuel Gauge is flashing every few seconds.**

**SOLUTION:**

1. This is LOW POWER MODE and is normal when the equipment/vehicle is not in use and helps conserve battery life. The flashing LED is still indicating the State of Charge of the battery.
2. Start using the equipment/vehicle and the LED light will stay on.

**PROBLEM: No LED indicators illuminated on Battery Fuel Gauge.**

**SOLUTION:**

1. Confirm that the wiring harness is connected properly to battery pack. (see pg. 11)
2. Check for corrosion on the battery post. Corrosion can cause a bad connection.
3. Call technical support for assistance – (800.742.2740)

**PROBLEM: After charging battery pack, the 9<sup>th</sup> LED does not illuminate, but a lower light does.**

**SOLUTION:**

1. This is an indication that the battery pack voltage is lower than what PCS would consider a full charge.
2. The equipment may have a small draw on the pack, which would cause the “static voltage” of the pack to be lower than what PCS would consider fully charged.
3. This may also indicate a low battery pack State of Health meaning that the batteries are not capable of providing the rated amount of capacity. In some instances, this could result in a slightly lower pack voltage than what PCS would consider fully charged.
4. Call technical support for further assistance – (800.742.2740)

**PROBLEM: The three AMBER LEDs slowly pulsing in and out and no State of Charge in the app.**

**SOLUTION:**

1. This indicates the gauge was setup for a Lithium application.
2. If you do not have a Lithium battery pack, please refer to page 10 for instructions on Battery Fuel Gauge configuration.
3. If you do have a Lithium battery pack, please refer to page 15 of this manual. If the procedure on page 15 does not solve your issue, please call technical support for further assistance – (800.742.2740)

# TROUBLESHOOTING

**PROBLEM:** The left most RED LED and right most GREEN LED are flashing.

**SOLUTION:**

1. This is an indicator that the Battery Fuel Gauge has attempted a firmware update but failed.
2. Open PROView Link and look for the below indication:

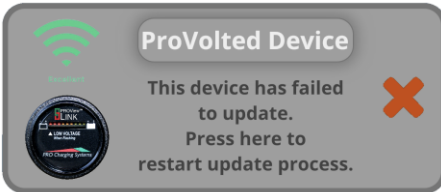

3. Tap on this indication and follow the next few prompts to restart the firmware update.
4. If the issue persists after multiple attempts, please contact technical support for further assistance – (800.742.2740)

# Over-The-Air Updates

The PCS Battery Fuel Gauge has the ability to receive functionality updates and bug fixes through wireless connection using the PROView Link App.

1. Download the latest version of PROView Link from the Google Play Store or the Apple App Store.
2. Once PROView Link is open, select your device from the Device screen.
3. If your device has an available Over-The-Air update, you will be prompted once you are connected.



FREE to Download

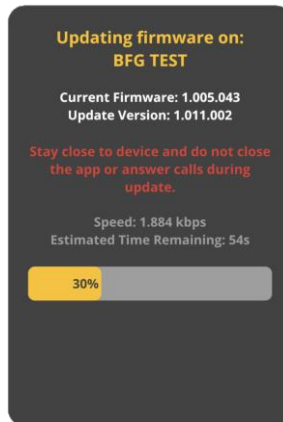
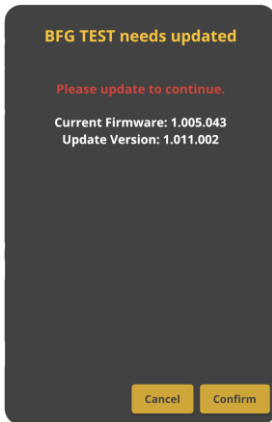

4. Tap the “CONFIRM” button. During the update, please do not walk away from your Battery Fuel Gauge or close the app.
5. If there is any issue during the update process in which you cannot see or connect to your Battery Fuel Gauge anymore, or you are seeing unusual LEDs, please see the last item of our troubleshooting section on the previous page (pg. 17)

# HOUSING DRAWINGS

## Round Battery Fuel Gauge

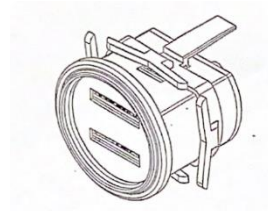
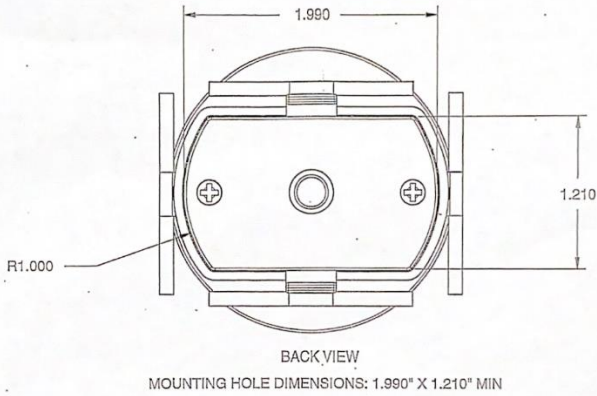

## Rectangle Battery Fuel Gauge

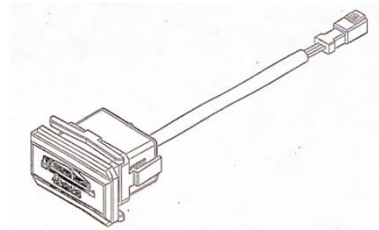
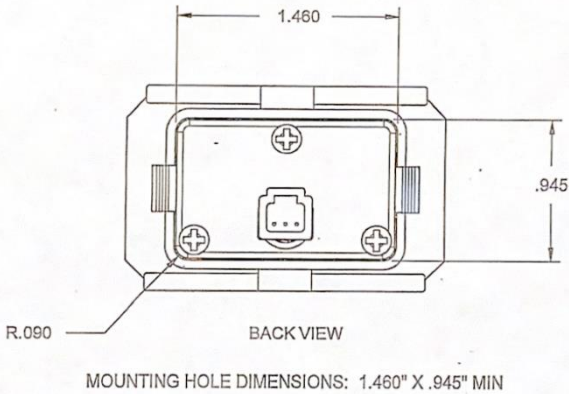

# THREE WIRE BFG WIRING

If your Battery Fuel Gauge (BFG) came equipped with three connection wires (black, red, and green), please refer to the following directions for proper installation. **It is important to note that improper installation can result in damage to the BFG.**

Note: The following instructions utilize a 36V series battery system for an example. The instructions also apply to all other battery system voltages (example: 24V, 48V, 72V, etc.)

**IMPORTANT: This model BFG utilizes the red wire to power the gauge. Always attach the red wire to the positive post of the same battery that has the black ground wire attached to the negative post.**

Please see diagram below which represents a 36V system utilizing three (3) 12 volt batteries in series:

- Attach the black wire (Ground) to the most negative (-) post of the series string. (Battery 1 in diagram below)
- Attach the red wire to the positive (+) post of the same battery. (Battery 1 in diagram below)
- Attach the green wire to the most positive post of the battery pack. (Battery 3 in diagram below)

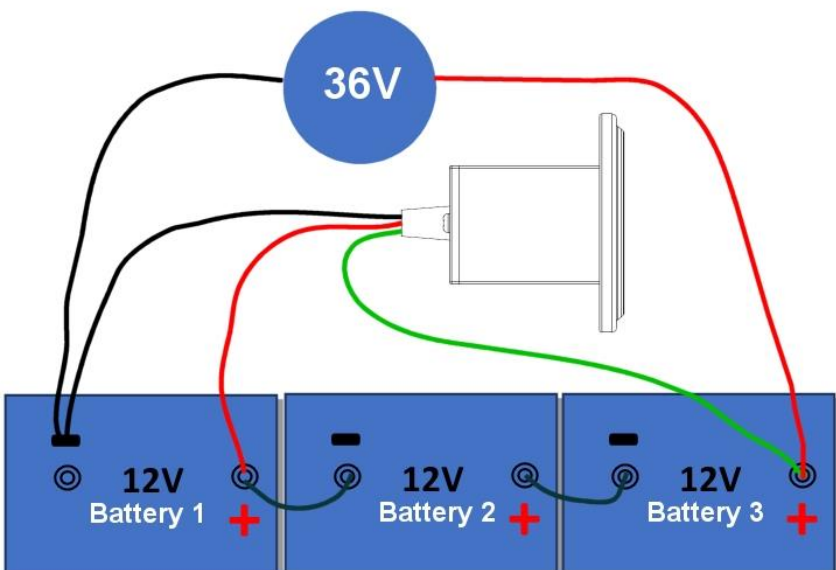

## ***LIMITED WARRANTY INFORMATION***

Pro Charging Systems, LLC (PCS) makes this Limited Warranty only to the original retail purchaser.

PCS warrants this Battery Fuel Gauge for one year from the date of retail purchase against discretion of the manufacturer. It is the responsibility of the original purchaser to return the Battery Fuel Gauge along with proof of purchase, transportation, and/or any mailing or handling charges prepaid to the manufacturer or its authorized representative.

This limited warranty is void if the product is misused, improperly maintained, handled carelessly or incorrectly operated. Additionally, this warranty is void if the Battery Fuel Gauge is disassembled, the connecting cables are cut, the connecting plugs are cut off, the Battery Fuel Gauge is altered without authorization from PCS, the serial number is removed, or repair is attempted by anyone other than an authorized representative.

PCS makes no other warranty other than this limited warranty and expressly excludes any implied warranty, including warranty for any incidental or consequential damages.

This is the only expressed limited one-year warranty authorized by PCS and does not authorize anyone to assume or make any other obligation towards the product other than this one-year Limited Warranty. Some state do not allow limitation of incidental or consequential damages.

This warranty gives you specific legal rights and you may also have other rights which vary from state to state. Please call Pro Charging Systems, LLC for full warranty information and/or service please call (800.742.2740).

Below are some of our other options in chargers and battery accessories. Call our technical support group for more detailed information or visit our web site [www.dualpro.com](http://www.dualpro.com).

# ADDITIONAL PRODUCTS

## Professional SERIES

15 Amp Independent Outputs  
One, two, three and four bank models



## Sportsman SERIES

10 Amp Independent Outputs  
One, two, three and four bank models

## Dual Power Charger

High Frequency Charger  
DP36/12 (charges a 36V system + a 12V system)



## Eagle Performance SERIES

Available in 12 to 72 Volts and  
12 to 50 Amps  
Many configurations and  
mounting options for many  
types of equipment



## RealPRO® SERIES

6 Amp  
Independent  
Outputs  
One, two and  
three bank  
models



## B.O.S. Battery Optimization System

Active battery  
balancing technology  
creates longer  
runtime, maximizes  
performance and  
extends battery life.



## Battery Fuel Gauges

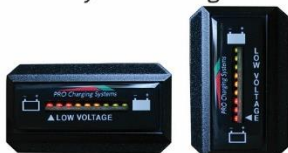

Onboard Electric Vehicle  
Horizontal and Vertical



Electric Vehicle  
Round



Watercraft  
Round



Lithium  
Round